

**Name:** \_\_\_\_\_  
**Date:** \_\_\_\_\_  
**Track:** \_\_\_\_\_

**Track Conditions**

Size:  Open  Med.  Tight  
 Traction:  High  Med.  Low  
 Surface:  Smooth  Med.  Bumpy

**Front suspension**

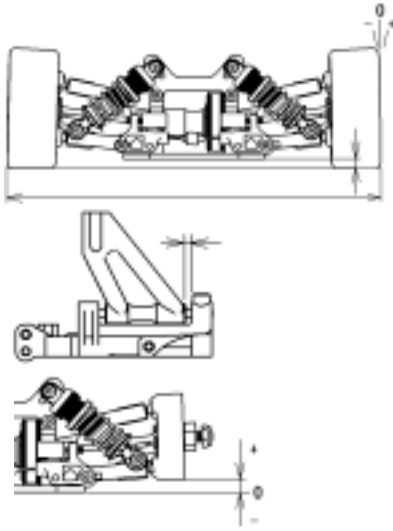

Track width 199 mm  
 Ride height 4 mm  
 Camber angle -2 °  
 Caster angle 2 mm  
 Toe angle out 0.5 °  
 Rebound stop 1 mm  
 Bump stop  
 None  Use

Anti-roll bar

**Steering Ackerman (T0304)**

A  B  C

**Front shocks**

Piston Stock  
 Oil # 600  
 Spring Blue

Shock position

**Front diff.**

Gear diff.  
 Oil # \_\_\_\_\_  
 One way

**Rear suspension**

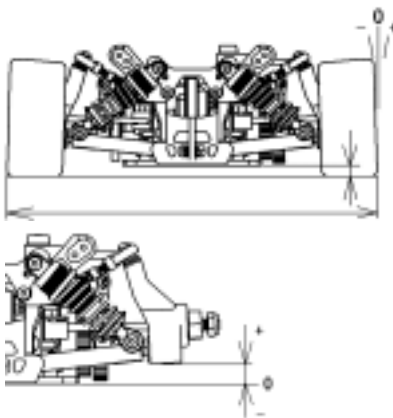

Track width 200 mm  
 Ride height 5 mm  
 Camber angle -4 °  
 Toe angle in 2.5 °  
 Rebound stop 6 mm  
 Bump stop  
 None  Use

Lower arm position(T0128,T0129)  
 4mm(A-A)  5mm(B-B)  6mm(C-C)  
 Anti-roll bar 2.5 mm

Upper arm position   
 1.5 mm

**Rear shocks**

Piston Stock  
 Oil # 600  
 Spring Blue

Shock position

**Rear diff.**

Oil # 10000

**Engine**

Type \_\_\_\_\_  
 Gasket \_\_\_\_\_ mm Muffler \_\_\_\_\_  
 Plug \_\_\_\_\_ Fuel \_\_\_\_\_

**Clutch**

Clutch shoes  Black  Gray  
 Centrifugal shoe Light Weight  
 Spring Super Hard  
 Clutch bell clearance 0.4 mm  
 Spring Adj. Nut position 0.8 mm

**Tire**

Front		Rear	
Type	_____	Type	_____
Dia.(start)	<u>  </u> L /R	Dia.(start)	<u>  </u> L /R
Dia.(finish)	<u>  </u> L /R	Dia.(finish)	<u>  </u> L /R

**Body**

Type \_\_\_\_\_  
 Wing \_\_\_\_\_

**Drive rati (0.8M)**

1st 21 / 59  
 2nd 27 / 53

**Brake pad**

Black  Yellow

**Result**

Race time / Lap \_\_\_\_\_  
 Best lap (1Lap) \_\_\_\_\_

**Comments:**

.....  
 .....  
 .....  
 .....