

Name: Kenji Osaka
Date: 12/1/2002
Track: WC Uruguay

Track Size: Open Med. Tight
Conditions Traction: High Med. Low
 Surface: Smooth Med. Bumpy

Front suspension

Camber angle -2.5 °
 Upper arm position 0 mm
 Toe angle 1 out °
 Rebound stop 28 mm
 Bump stop
 None Use
 Anti-roll bar
 None Use 2.3 mm

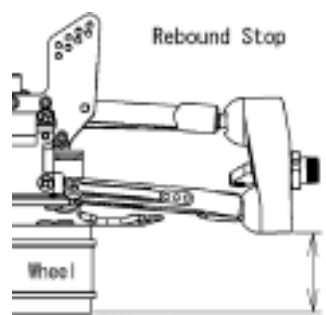
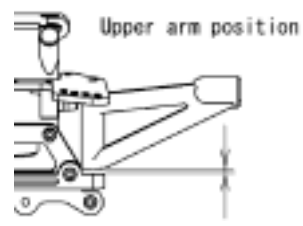

Shocks

Piston 1.5X2
 Oil # 400
 Spring White
 Spacer _____ mm

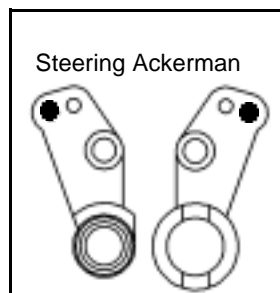
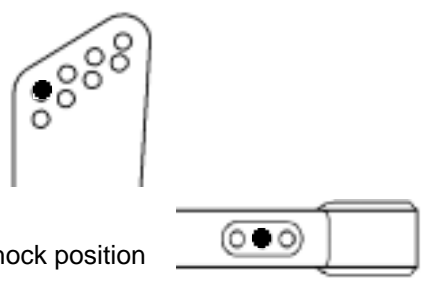

Rear suspension

Camber angle -3.5 °
 Toe angle A 1.2 mm
 B 0.8 mm
 Rebound stop 25 mm
 Bump stop
 None Use
 Anti-roll bar
 None Use 2.8 mm

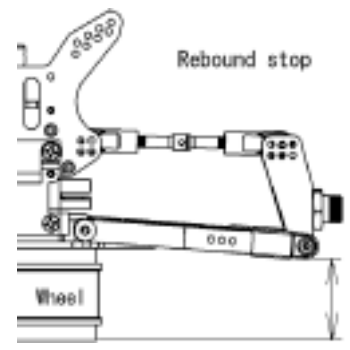
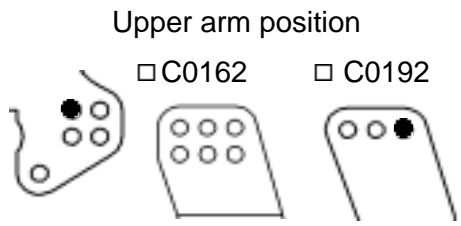
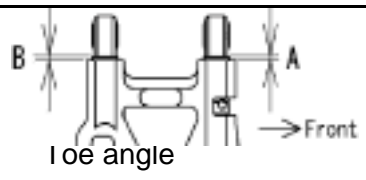

Shocks

Piston 1.5X2
 Oil # 400
 Spring White
 Spacer _____ mm

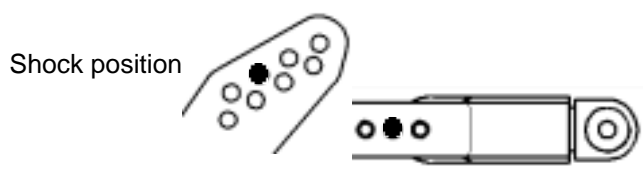

Engine Type NOVA RX21P5
 Gasket 0.7 mm Muffler 053
 Plug C6TGC Fuel MSRF30

Diff. Oil Front # 3000
 Center # 5000
 Rear # 1000 w/o. O-Ring

Tires **Front** Type Crime Fighter M2 Insert Mugen L
Rear Type Crime Fighter M2 Insert Mugen L

Clutch Clutch shoes Black Aluminium
 White
 Spring 1.0 mm
 Clutch bell 14-4€ T

Result
 Race time / Lap _____
 Best lap (1Lap) _____

Comments:

