

**Name:** Kenji Osaka  
**Date:** 10/27/2001  
**Track:** SS Hobby Circuit

**Track** Size:  Open  Med.  Tight  
**Conditions** Traction:  High  Med.  Low  
 Surface:  Smooth  Med.  Bumpy

### Front suspension

Camber angle -2.5 °  
 Upper arm position 2 mm  
 Toe angle 1.5 out °  
 Rebound stop 30 mm  
 Bump stop  
 None  Use  
 Anti-roll bar  
 None  Use 2.3 mm

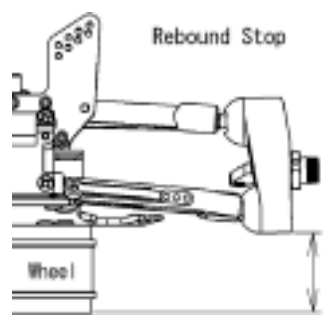
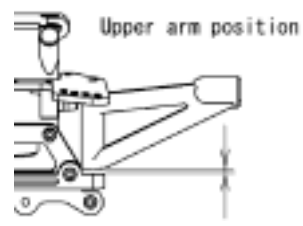

### Shocks

Piston 1.5x2  
 Oil # 400  
 Spring Light Blue  
 Spacer 4 mm

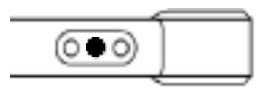
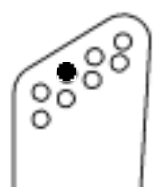

### Steering Ackerman

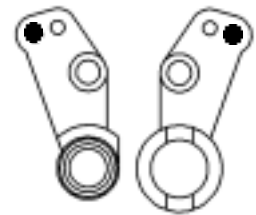

### Rear suspension

Camber angle -3.5 °  
 Toe angle A 0.4 mm  
           B 0.8 mm  
 Rebound stop 29 mm  
 Bump stop  
 None  Use  
 Anti-roll bar  
 None  Use 2.8 mm

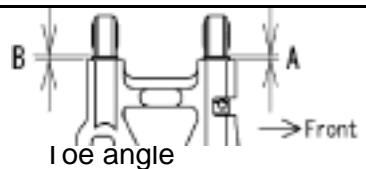

### Upper arm position

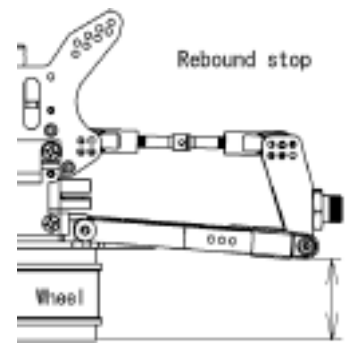
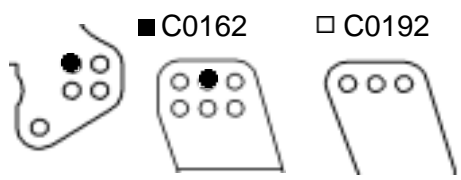

### Shocks

Piston 1.5X2  
 Oil # 400  
 Spring Light Blue  
 Spacer 7 mm

### Shock position

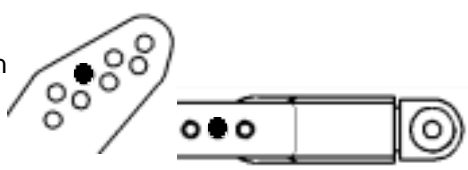

### Wing Position

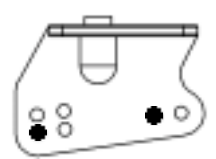

**Engine** Type NOVA RX21BK  
 Gasket 0.5 mm Muffler 053 w/Flange Pol.  
 Plug C6G Fuel Bylon 3000

**Diff. Oil** Front # BBF Tactyl II  
 Center # BBF Tactyl II  
 Rear # 1000

**Tires** **Front** Type Crime Fighter M2 Insert Mugen L  
**Rear** Type Crime Fighter M2 Insert Mugen L

**Clutch** Clutch shoes  Black  Aluminum  White  
 Spring 1.0 mm  
 Clutch bell 13 T

**Result**  
 Race time / Lap \_\_\_\_\_  
 Best lap (1Lap) \_\_\_\_\_

**Comments:**  
 Use new damper and spring for Fornt and Rear  
 Use BBF Tactyl II Diff. for Front and Center  
 Rear Diff. w/o. O-Ring