

Name : _____
 Date : _____
 Track : _____

Track	Size:	<input type="checkbox"/> Open	<input type="checkbox"/> Med.	<input type="checkbox"/> Tight
Conditions	Traction:	<input type="checkbox"/> High	<input type="checkbox"/> Med.	<input type="checkbox"/> Low
	Surface:	<input type="checkbox"/> Smooth	<input type="checkbox"/> Med.	<input type="checkbox"/> Bumpy

Front suspension

Camber angle -2 °
 Upper arm position 2 mm
 Toe angle 0 °
 Rebound stop 30 mm
 Bump stop
 None Use
 Anti-roll bar
 None Use φ2.1 mm

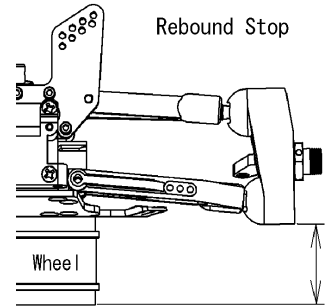
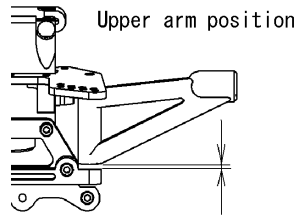

Shocks

Piston Stock
 Oil # 350
 Spring Stock
 Spacer 3 mm

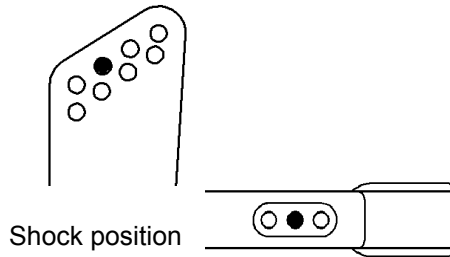

Steering Ackerman

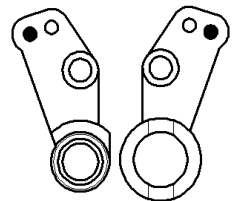

Rear suspension

Camber angle -3 °
 Toe angle A 2.5 mm
 B 2.5 mm
 Rebound stop 25 mm
 Bump stop
 None Use
 Anti-roll bar
 None Use φ2.6 mm

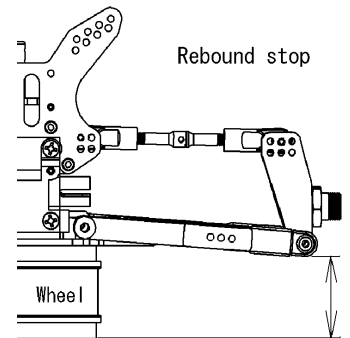
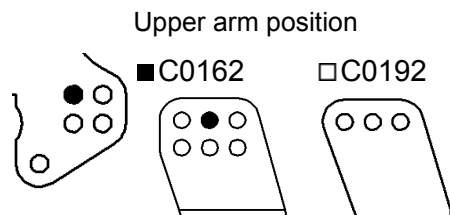
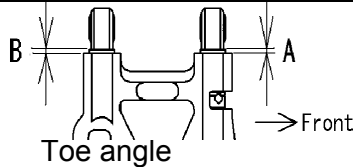

Shocks

Piston Stock
 Oil # 350
 Spring Stock
 Spacer 5 mm

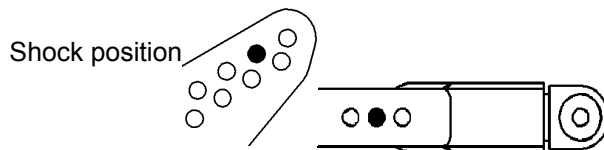

Wing Position

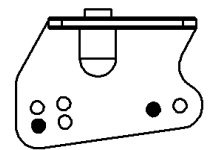

Engine Type _____
 Gasket _____ mm Muffler _____
 Plug _____ Fuel _____

Diff. Oil Front # 3,000
 Center # 7,000
 Rear # 1,000

Tires **Front** Type _____
 Insert _____
Rear Type _____
 Insert _____

Clutch Clutch shoes Black
 White
 Spring Stock mm
 Clutch bell 14 T

Result
 Race time / Lap _____
 Best lap (1Lap) _____

Comments :

