

**Name :** Kenji Osaka  
**Date :** 4/2/2000  
**Track :** Futaba Buggy Truck

**Track** Size:  Open  Med.  Tight  
**Conditions** Traction:  High  Med.  Low  
 Surface:  Smooth  Med.  Bumpy

### Front suspension

Camber angle -2 °  
 Upper arm position 4 mm  
 Toe angle out 1 °  
 Rebound stop 30 mm  
 Bump stop  
 None  Use  
 Anti-roll bar  
 None  Use 2.1 mm

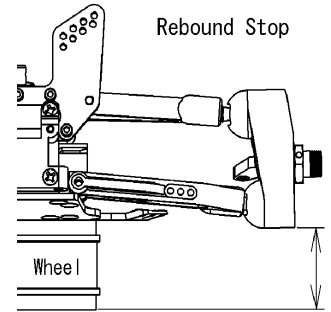
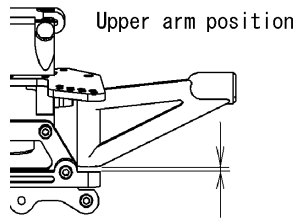

### Shocks

Piston 1.3X2  
 Oil # 300  
 Spring Silver  
 Spacer 4 mm

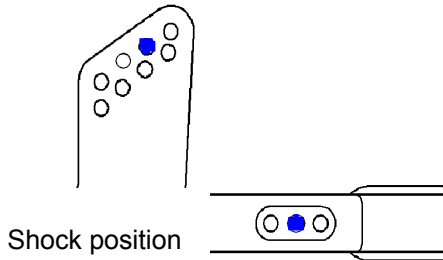

### Rear suspension

Camber angle -3 °  
 Toe angle A 2 mm  
           B 2 mm  
 Rebound stop 25 mm  
 Bump stop  
 None  Use  
 Anti-roll bar  
 None  Use 2.6 mm

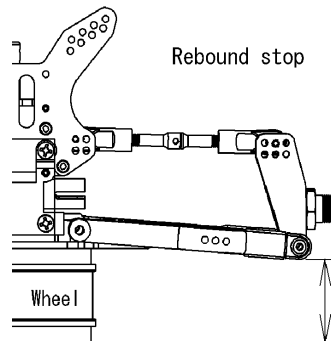
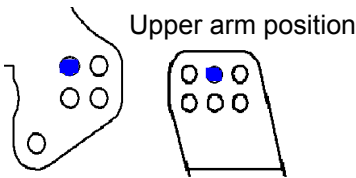
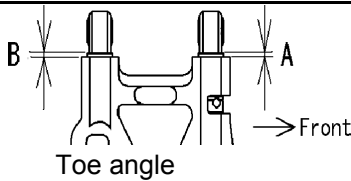

### Shock

Piston 1.3X2  
 Oil # 300  
 Spring Silver  
 Spacer 5 mm

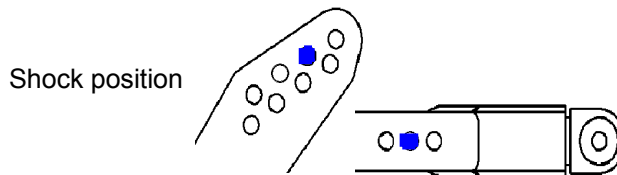

**Engine** Type NOVA BX21 BK  
 Gasket 0.6 mm Muffler NOVA053  
 Plug C7S Fuel Cosmo 30%

**Diff. Oil** Front # 3000  
 Center # 5000  
 Rear # 1000

**Tires** **Front** Type MICRO XXC Insert Mugen L  
**Rear** Type MICRO XXC Insert Mugen L

**Clutch** Clutch shoes  Black  White  
 Spring 0.9 mm  
 Clutch bell 14 T

**Result**  
 Race time / Lap \_\_\_\_\_  
 Best lap (1Lap) \_\_\_\_\_

**Comments** Truck View : <http://www.mugenseiki.com/futaba2000.htm>  
 \_\_\_\_\_  
 \_\_\_\_\_  
 \_\_\_\_\_  
 \_\_\_\_\_