

**Name:** \_\_\_\_\_  
**Date:** \_\_\_\_\_  
**Track:** \_\_\_\_\_

### Track Conditions

Size:	<input type="checkbox"/> Open	<input type="checkbox"/> Med.	<input type="checkbox"/> Tight
Traction:	<input type="checkbox"/> High	<input type="checkbox"/> Med.	<input type="checkbox"/> Low
Surface:	<input type="checkbox"/> Smooth	<input type="checkbox"/> Med.	<input type="checkbox"/> Bumpy

### Front Suspension

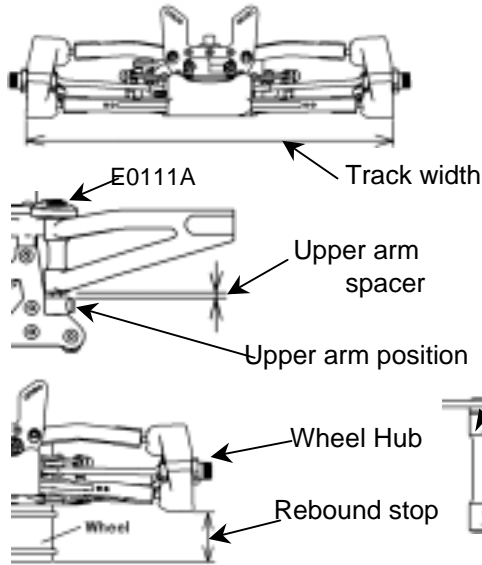

Track width	<u>276</u> mm
Camber angle	<u>-2</u> °
Upper arm spacer	<u>2</u> mm
Toe angle	<u>OUT 0.5</u> °
Rebound stop	<u>26</u> mm
Anti-roll bar	<u>2.3</u> mm
Wheel Hub	<u>0</u> mm
Lower arm mount (Kick up)	<u>-2</u> °
Upper arm position (E0111A)	<input type="checkbox"/> <input type="checkbox"/>
Lower arm spacer	<u>0</u> mm

- E0106A - E0106B (High)  
 E0106C - E0106D (Low)

### Front Shocks

Piston	<u>Stock</u>
Oil #	<u>350</u>
Spring	<u>Stock</u>
Spacer	<u>2</u> mm

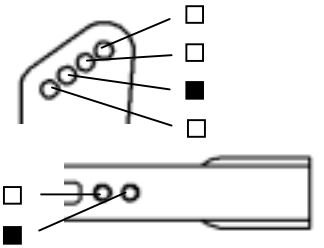

### Steering Ackerman

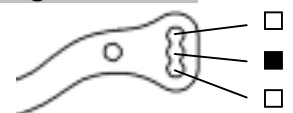

### Rear Suspension

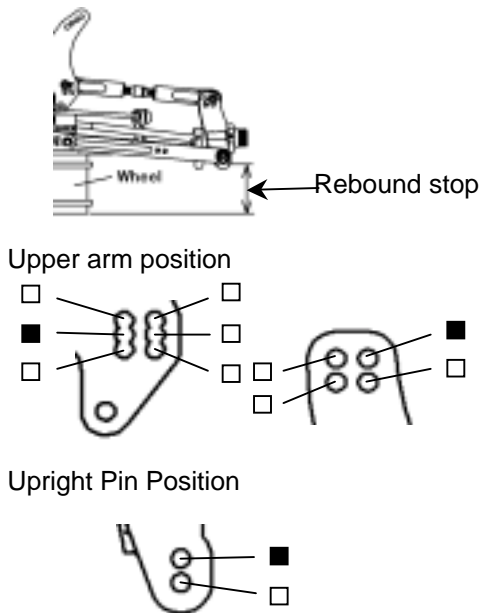

Camber angle	<u>-3</u> °
Lower arm mount (Toe angle)	<u>3</u> °
Rebound stop	<u>23</u> mm
Anti-roll bar	<u>2.8</u> mm
Anti-squat (E0111C, E0111D)	<input type="checkbox"/> <input type="checkbox"/> <input type="checkbox"/>
Upright	<input checked="" type="checkbox"/> E0110 <input type="checkbox"/> E0126(Aluminium)
Wheelbase adjustment	<u>5</u> mm

### Rear Shocks

Piston	<u>Stock</u>
Oil #	<u>350</u>
Spring	<u>Stock</u>
Spacer	<u>4</u> mm

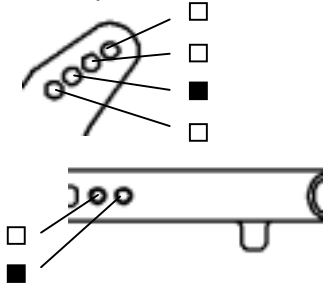

### Wing Position

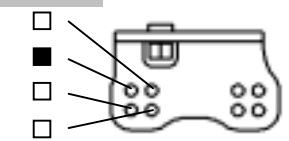

<b>Engine</b> Type	_____
Gasket	_____ mm Reducer $\phi$ _____
Plug	_____ Fuel _____
Muffler	_____

<b>Diff. Oil</b>	
Front	# <u>3000</u> O-Ring <u>4</u> pcs. <input type="checkbox"/> Other _____
Center	# <u>3000</u> <u>2</u> pcs. <input type="checkbox"/> Other _____
Rear	# <u>1000</u> <u>-</u> pcs. <input type="checkbox"/> Other _____

<b>Tire</b>	
<b>Front</b>	<b>Rear</b>
Type _____	Type _____
Foam _____	Foam _____

<b>Clutch</b>	
Clutch shoes	<input checked="" type="checkbox"/> Aluminium <input type="checkbox"/> Other _____
Spring	<u>1.0</u> mm
Clutch bell / Spur gear	<u>13T / 46T</u>

<b>Result</b>	
Race time / Lap	_____
Best lap (1Lap)	_____

**Comments:**

.....

.....

.....

.....