

Name: Juan C. Rodriguez
 Date: 24-2-2008
 Track: Isabela B/c Track

Track conditions
 Size: Open Med. Tight
 Traction: High Med. Low
 Surface: Smooth Med. Bumpy

Front suspension

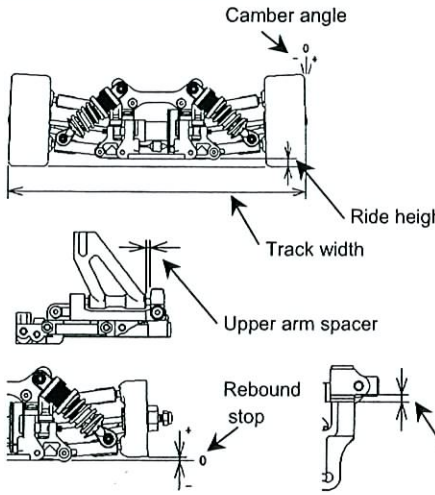

Track width 198 mm
 Ride height 5.5 mm
 Camber angle 2 °
 Upper arm spacer 2 mm
 Toe angle out 1 °
 Rebound stop 0 mm
 Bump stop None Use
 Upper arm position 1 - 1.5 mm
 Anti-roll bar
 Upright T0138-B T0164
 Upper arm position 1 mm

Front shock

Piston stacks
 Oil # 600
 Spring light Blue
 Sock position

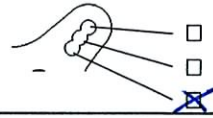

Front Diff.

One way
 Gear diff. Oil # 100,000
 Solid

Steering ackerman

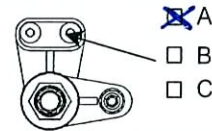

Rear suspension

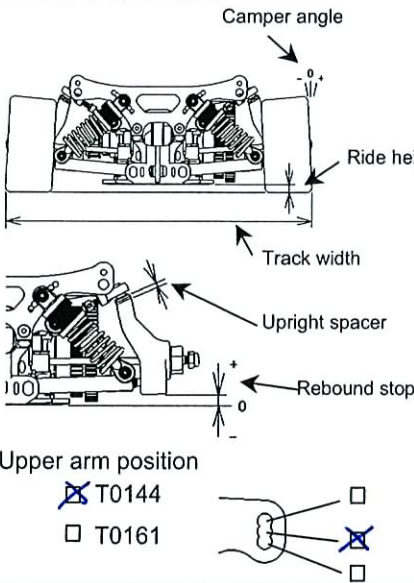

Track width 200 mm
 Ride height 6.5 mm
 Camber angle -3 °
 Toe angle in 2.5 °
 Rebound stop 5 mm
 Bump stop None Use
 Lower arm position
 Upright spacer 1 mm
 Anti-roll bar Wire ϕ 2.2
0 mm
 Adjustable(T0162)
 Upright T0144 T0161
 Wheel Hub Spacer 1 mm

Rear Shock

Piston stacks
 Oil # 600
 Spring light Blue
 Shock position

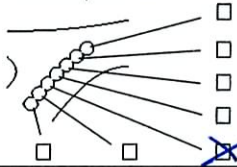

Rear Diff.

Oil # 30,000

Engine Type Ninja
 Gasket 0.5 mm Muffler Ninja Tune Pipe
 Plug 6 nova Fuel Maxy's fuel 30%

Tire <Front> Type Jaco <Rear> Type Jaco
 Dia.(start) L /R Dia.(start) L /R
 Dia.(finish) L /R Dia.(finish) L /R

Clutch

Clutch shoe Black Gray Yellow
 Centrifugal shoe light weight
 Spring Ofion
 Clutch bell clearance .55 mm
 Spring adj. Nut position n/a mm

Brake pad

Black Other

Body

Type stratus 3.1
 Wing center

Drive ratio

Gear ratio Side pulley
 1st. 17 / 60 24T
 2nd. 23 / 54 25T

Result

Race time / Lap 152 / 45:07.58
 Best lap (1Lap) 16.0

Comments:

.....

