

Driver : _____
 Date : _____
 Track : _____
 Event : _____

Track Condition
 Size : Open Med. Tight
 Traction : High Med. Low
 Condition : Smooth Bumpy Dry Wet
 Dusty Grooved Hard Packed

Front Suspension

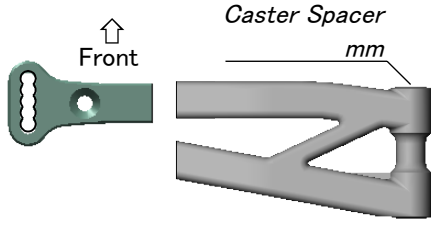
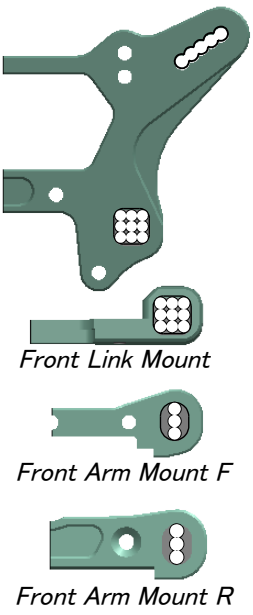

Upper : Alu. Steel
 Lower : Alu. Steel

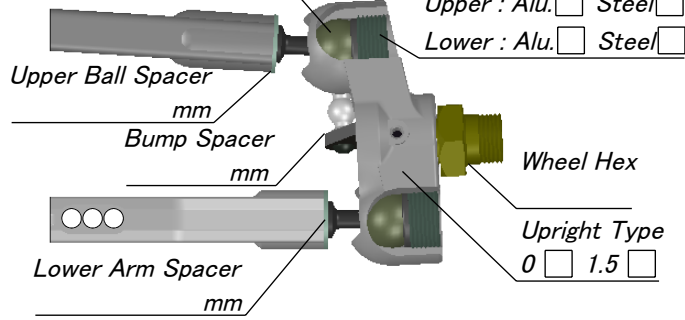

Ride Height :	Toe :
Anti-roll Bar :	
F Upright Arm : 0 Dot <input type="checkbox"/> 1 Dot <input type="checkbox"/>	
Drive Shaft : CVA <input type="checkbox"/> Universal <input type="checkbox"/>	
Chassis Brace : Short <input type="checkbox"/> Long <input type="checkbox"/>	
Servo Saver Arm : STD. <input type="checkbox"/> Alu. <input type="checkbox"/>	
Servo Horn : STD. <input type="checkbox"/> Alu. <input type="checkbox"/>	
Length :	

Rear Suspension

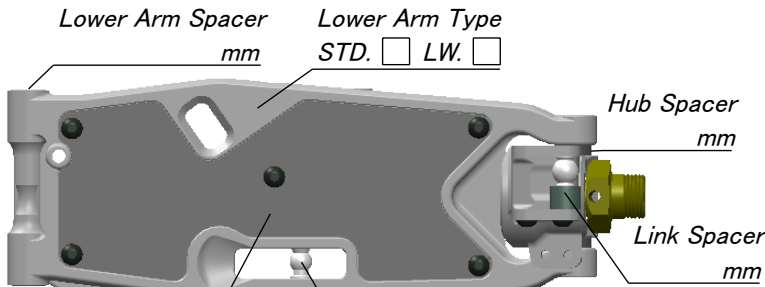
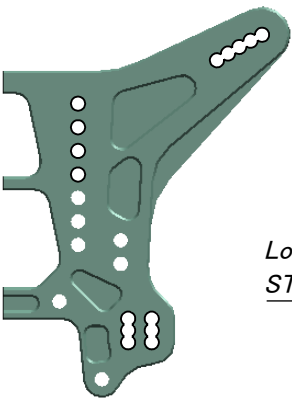

Ball Position : Forward Back

Ride Height :	Camber :
Rear Hub : Plastic <input type="checkbox"/> Alu. <input type="checkbox"/>	
Anti-Roll Bar :	
Drive Shaft : CVA <input type="checkbox"/> Universal <input type="checkbox"/>	
Rear Link Plate : 1Dot <input type="checkbox"/> 3Dot <input type="checkbox"/>	
Dot Orientation : In <input type="checkbox"/> Out <input type="checkbox"/>	

Shocks	Front		Rear		Differential Oil		Front		Center		Rear	
	 Length	Piston										
	Oil											
	Spring											
	Bladder	<input type="checkbox"/>		<input type="checkbox"/>								
	Emulsion	<input type="checkbox"/>		<input type="checkbox"/>								
	Length		mm		mm							
	Notes :											

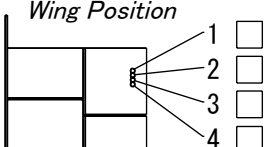
Engine		Body & Wing		Differential Oil		Front		Center		Rear	
Type		Body									
Muffler		Wing									
Manifold		Front Wing									
Fuel		Gap to Tower									
Reducer		Wing Position									
Grow Plug											
Engine Mount : STD. <input type="checkbox"/> 1pc. <input type="checkbox"/>											
				Inserts							
				Wheel							
				Chassis Weight		Front : g		Rear : g			
				Notes :							