

Driver : \_\_\_\_\_  
 Date : \_\_\_\_\_  
 Track : \_\_\_\_\_  
 Event : \_\_\_\_\_

Track Condition  
 Size : Open  Med.  Tight   
 Traction : High  Med.  Low   
 Condition : Smooth  Bumpy  Dry  Wet   
 Dusty  Grooved  Hard Packed

### Front Suspension

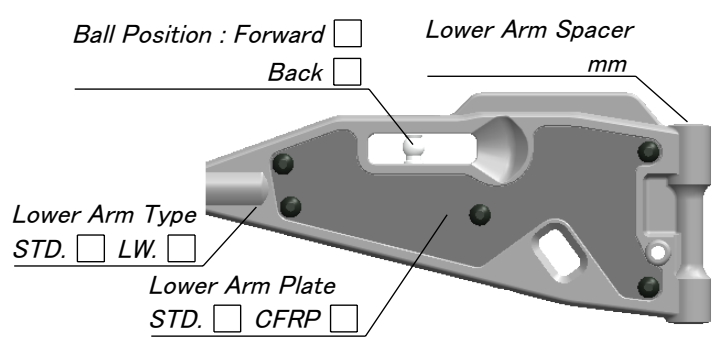
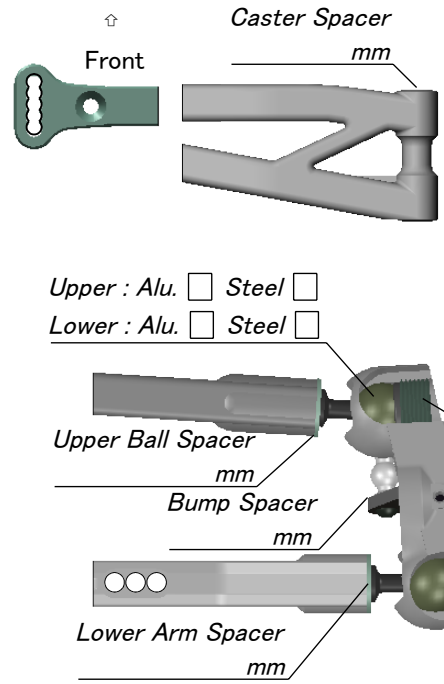
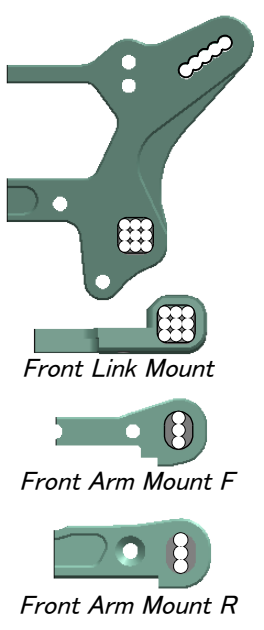

Ride Height : \_\_\_\_\_ Toe : \_\_\_\_\_  
 Anti-roll Bar : \_\_\_\_\_  
 F Upright Arm : 0 Dot  1 Dot   
 Drive Shaft : CVA  Universal   
 Chassis Brace : Short  Long   
 Servo Saver Arm : STD.  Alu.   
 Servo Horn : STD.  Alu.   
 Length : \_\_\_\_\_

### Rear Suspension

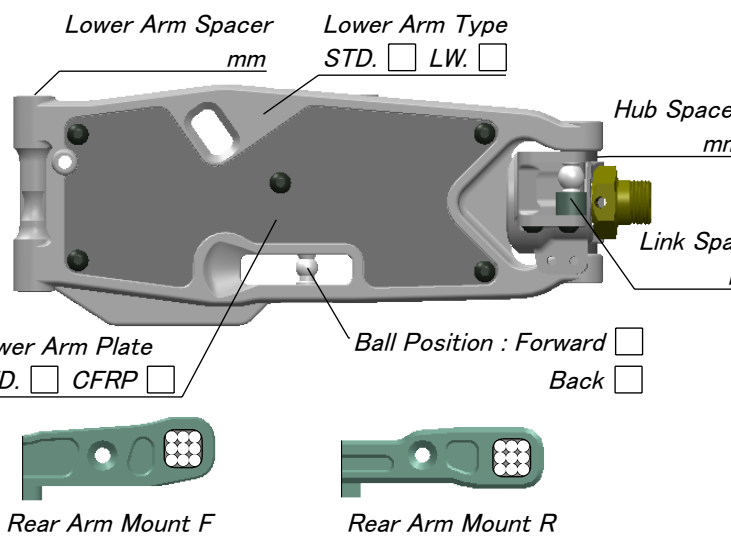
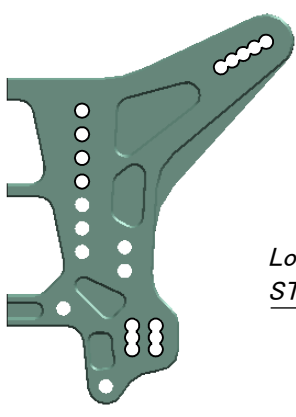

Wheel Hex  
 Ride Height : \_\_\_\_\_ Camber : \_\_\_\_\_  
 Rear Hub : Plastic  Alu.   
 Anti-Roll Bar : \_\_\_\_\_  
 Drive Shaft : CVA  Universal   
 Rear Link Plate : 1Dot  3Dot   
 Dot Orientation : In  Out

Shocks	Front	Rear
	Piston	
Oil		
Spring		
Bladder	<input type="checkbox"/>	<input type="checkbox"/>
Emulsion	<input type="checkbox"/>	<input type="checkbox"/>
Length	mm	mm
Notes :		

Differential Oil	Front	Center	Rear
	Center Drive Shaft	Dog Born <input type="checkbox"/> Universal <input type="checkbox"/>	
Clutch & Gearing	Spur Gear	T	Bell T
Spring Position :	Dot <input type="checkbox"/> Non Dot <input type="checkbox"/>	3Pin <input type="checkbox"/> 4Shoe <input type="checkbox"/>	
Shoe :			
Spring :			

Engine	Body & Wing	
Type	Body	
Muffler	Wing	
Manifold	Front Wing	
Fuel	Gap to Tower	
Reducer	Wing Position	
Grow Plug		
Engine Mount :	STD. <input type="checkbox"/> 1pc. <input type="checkbox"/>	

Tire	Front	Rear
Type		
Compound		
Inserts		
Wheel		
Chassis Weight	Front : _____ g	Rear : _____ g
Notes :		