

**Name:** Kenji Osaka  
**Date:** \_\_\_\_\_  
**Track:** Futaba Buggy Tract

### Track Conditions

Size:  Open  Med.  Tight  
 Traction:  High  Med.  Low  
 Surface:  Smooth  Med.  Bumpy

### Front Suspension

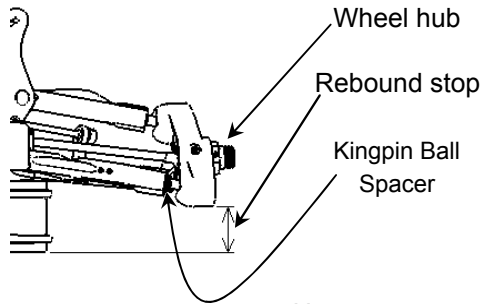

Kingpin ball spacer 1 mm  
 Camber angle -2 °  
 Upper arm spacer 2 mm  
 Toe angle out 1 °  
 Rebound stop 12 mm  
 Anti-roll bar  $\phi$  2.3 mm  
 Wheel Hub 0 mm  
 Lower arm mount (Kick up)  0  1



Lower arm plate (E0154A)

Upper arm position (E0148B, E0148C)

Lower arm spacer 0 mm

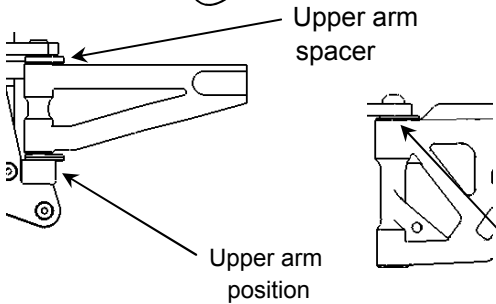

### Front Shocks

Piston 1.35x5  
 Oil # 400  
 Spring 10.0x75  
 Spring adjustmer 5.5 mm

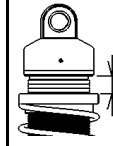

Shock position

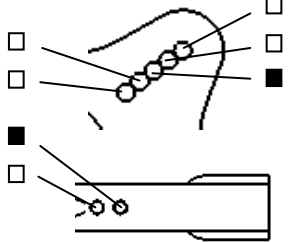

### Steering Ackerman

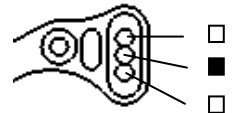

### Rear Suspension

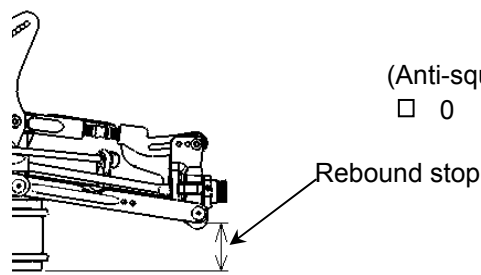

Camber angle -2.5 °  
 Lower arm mount (Anti-squat)  0  1  
 (Toe angle) 3 °  
 Rebound stop 12 mm  
 Anti-roll bar  $\phi$  2.8 mm  
 Anti-squat (E0111C, E0111D)



Upright  E0152  E0173 (Aluminium)

Wheelbase adjustment

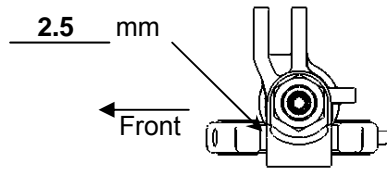

Lower arm spacer 0 mm

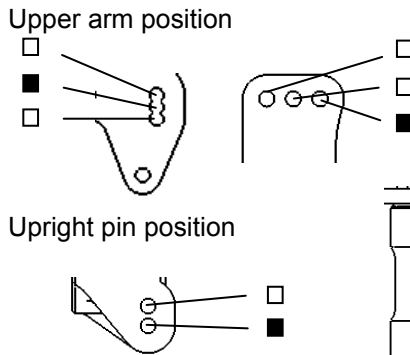

### Rear Shocks

Piston 1.35x5  
 Oil # 350  
 Spring 10.75x86  
 Spring adjustmer 10 mm

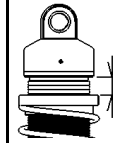

Shock position

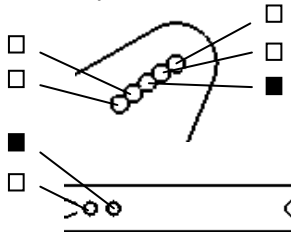

### Wing Position

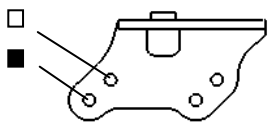

**Engine** Type Ninja JX21-B01A  
 Gasket 0.3 mm Reducer  $\phi$  6.5  
 Plug P4 Fuel MSRF  
 Muffler Ninja 2042

**Diff. Oil**  
 Front # 7000 O-Ring 0 pcs.  Other \_\_\_\_\_  
 Center # 4000 0 pcs.  Other \_\_\_\_\_  
 Rear # 2000 0 pcs.  Other \_\_\_\_\_

**Tire**  
**Front**  
 Type \_\_\_\_\_  
 Foam \_\_\_\_\_  
**Rear**  
 Type \_\_\_\_\_  
 Foam \_\_\_\_\_

**Clutch**  
 Clutch shoes  Aluminium \_\_\_\_\_  
 Other \_\_\_\_\_  
 Spring 0.9, 1.0, 1.0 mm  
 Clutch bell / Spur gear 13T / 44T

**Result**  
 Race time / Lap \_\_\_\_\_  
 Best lap (1Lap) \_\_\_\_\_

**Comments:**  
 \_\_\_\_\_  
 \_\_\_\_\_  
 \_\_\_\_\_  
 \_\_\_\_\_