

Name: Keisuke Fukuda
 Date: 9/13/09
 Track: Hokusei Circuit

Track conditions

Size: Open Med. Tight
 Traction: High Med. Low
 Surface: Smooth Med. Bumpy

Front suspension

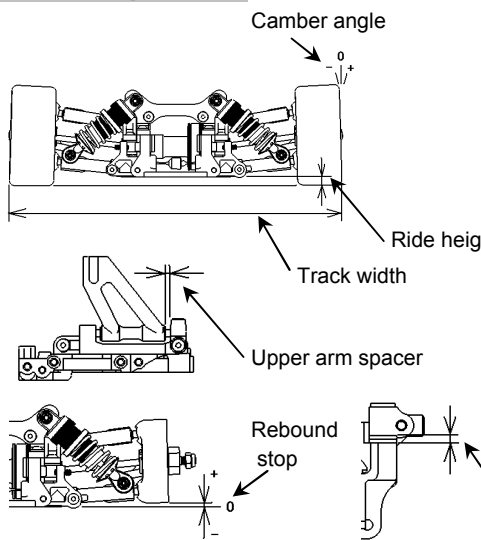

Track width 199 mm
 Ride height 6 mm
 Camber angle -1.5 °
 Upper arm spacer 3 mm
 Toe angle out 1.5 °
 Rebound stop 0 mm
 Bump stop None Use
 Upper arm position 1 mm
 Anti-roll bar T0138-B T0164
 Upright T0138-B T0164
 Upper arm position 1 mm

Front shock

Piston 1.3x1
 Oil # 600
 Spring Light blue
 Sock position

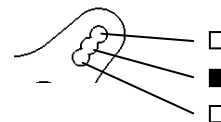

Front Diff.

One way
 Gear diff. Oil # 30,000
 Solid

Steering ackerman

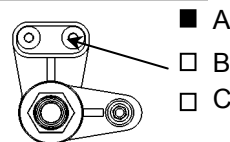

Rear suspension

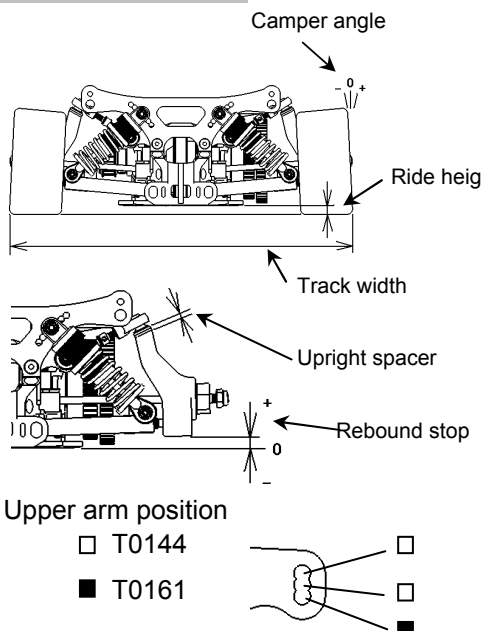

Track width 200 mm
 Ride height 7 mm
 Camber angle -4.0 °
 Toe angle in 2.5 °
 Rebound stop 4 mm
 Bump stop None Use
 Lower arm position
 Upright spacer 3 mm
 Anti-roll bar Wire
 φ 2.2
 Adjustable(T0162) 0 mm
 Wheel Hub Spacer 1 mm

Rear Shock

Piston 1.1x2
 Oil # 600
 Spring Light blue
 Shock position

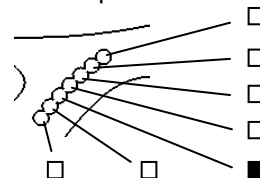

Rear Diff.

Oil # 30,000

Engine Type Novarossi 353 09
 Gasket mm Muffler Novarossi
 Plug 7TGF Fuel

Tire <Front> Type ZAC 811C <Rear> Type ZAC 37
 Dia.(start) L 60 /R 60 Dia.(start) L 62 /R 61
 Dia.(finish) L /R Dia.(finish) L /R

Clutch

Clutch shoe Black Gray Yellow
 Centrifugal shoe
 Spring Super hard
 Clutch bell clearance 0.5 mm
 Spring adj. Nut position 1.2 mm

Brake pad

Black Other

Body Type Protoform DNA
 Wing

Drive ratio

Gear ratio Side pulley
 1st. 17 / 60 24T
 2nd. 23 / 53 25T

Result
 Race time / Lap
 Best lap (1Lap)

Comments: Use Serpent clutch

