

DATE	03.03.2019	
DRIVER	Pietsch/Kutvonen	
TRACK	TITC	
CARPET	<input type="checkbox"/> ASPHALT	<input checked="" type="checkbox"/>
TRACTION		
LOW	MEDIUM	HIGH <input checked="" type="checkbox"/>
LAYOUT		
SLOW	MIXED <input checked="" type="checkbox"/>	FAST
ELECTRIC'S		
STEERING SERVO	TYPE	SETTINGS
ESC	TYPE	SETTINGS
ENGINE	TYPE	SETTINGS
TYRES/ADDITIVE	TYPE	TYPE

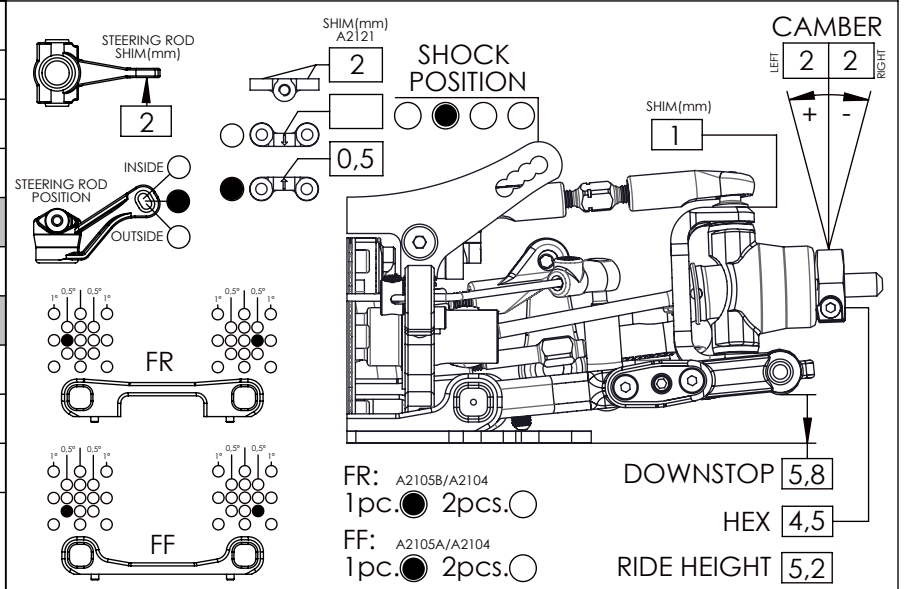

FRONT FULL <input checked="" type="checkbox"/>	REAR FULL <input checked="" type="checkbox"/>
MIN. 5	MIN. 5
SHOCK ABSORBERS	
FRONT	REAR
PISTON kit	PISTON kit
OIL 450	OIL 450
SPRING XR 2,6	SPRING XR 2,6
ANTI ROLL BAR FRONT	
1,2 <input type="checkbox"/> 1,3 <input checked="" type="checkbox"/> 1,4 <input type="checkbox"/> 1,5 <input type="checkbox"/>	
ANTI ROLL BAR REAR	
1,1 <input type="checkbox"/> 1,2 <input type="checkbox"/> 1,3 <input checked="" type="checkbox"/> 1,4 <input type="checkbox"/>	
SERVO SAVER POSITION	
FORWARD <input type="checkbox"/>	REARWARD <input checked="" type="checkbox"/>
PINION	SPUR
DIFF	SPOOL
HIGH <input checked="" type="checkbox"/>	HIGH <input checked="" type="checkbox"/>
LOW <input type="checkbox"/>	LOW <input type="checkbox"/>
DIFF OIL CST	8000K 1,3g.

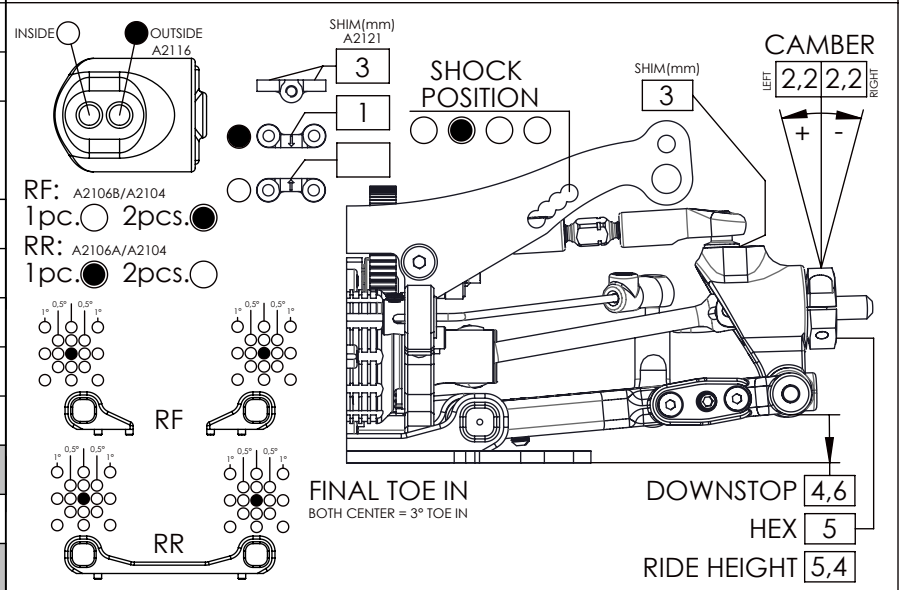

SERVO SAVER POSITION	
FORWARD <input type="checkbox"/>	REARWARD <input checked="" type="checkbox"/>
PINION	SPUR
DIFF	SPOOL
HIGH <input checked="" type="checkbox"/>	HIGH <input checked="" type="checkbox"/>
LOW <input type="checkbox"/>	LOW <input type="checkbox"/>
DIFF OIL CST	8000K 1,3g.

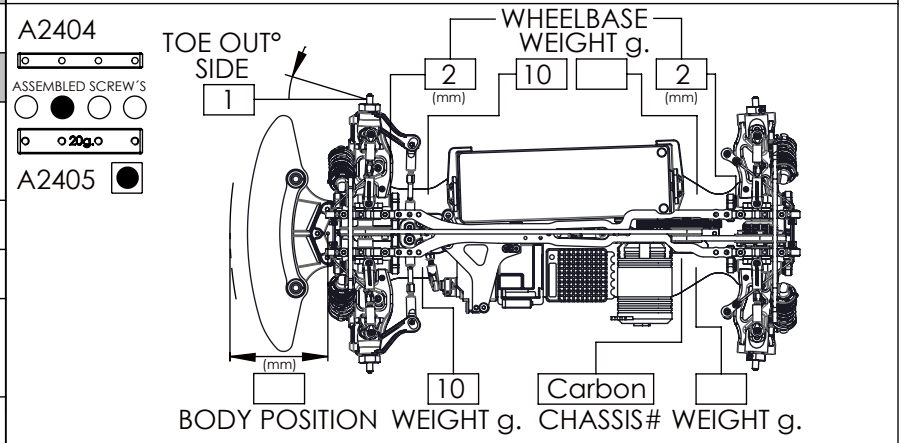

SHOCK POSITION LOWER ARM	
PART#	FRONT kit
HOLE POSITION BALL LINK INSIDE <input type="checkbox"/>	HOLE POSITION BALL LINK INSIDE <input type="checkbox"/>
HOLE POSITION BALL LINK OUTSIDE <input checked="" type="checkbox"/>	HOLE POSITION BALL LINK OUTSIDE <input checked="" type="checkbox"/>

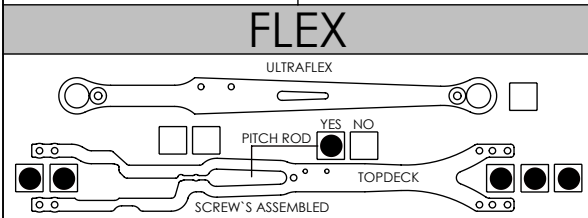
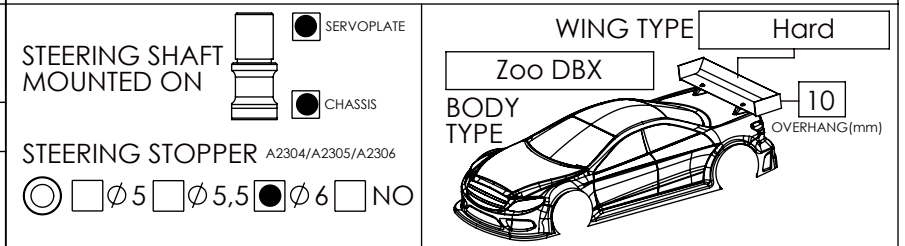

NOTES:
-Servoplate connected with servoshaft (#A2309)