

DRIVER				
DATE				
TRACK				
TRACTION	<input type="radio"/> LOW	<input type="radio"/> MEDIUM	<input type="radio"/> HIGH	
LAYOUT	<input type="radio"/> SLOW	<input type="radio"/> MIXED	<input type="radio"/> FAST	
TEMP °C	AIR	TRACK		
ENGINE				
TYPE	MANIFOLD	PIPE		
TIRES				
BRAND				
SHORE	FRONT	REAR		
SIZE (mm)				
TREAT				
SHOCK ABSORBERS				
PISTON	FRONT	REAR		
OIL				
SPRING	Mugen White	Serpent Blue		
ANTI ROLL BAR FRONT/REAR				
<input type="radio"/> 2,2	<input type="radio"/> 2,3	<input type="radio"/> 2,4	<input type="radio"/> 2,5	
<input type="radio"/> 2,8	<input type="radio"/> 2,9	<input type="radio"/> 3,0		
INSERT	<input type="radio"/> 10	ACKERMANN		
T2303N(8)	<input type="radio"/> T2303J(9)	<input type="radio"/> T2303i(10)		
INSERT		POSITION		
LONG	<input type="radio"/> CENTER	<input type="radio"/> SHORT	<input type="radio"/>	
CLUTCH SETTINGS				
BELL#	SHOE#	SPRING#		
GAP(mm)	PLAY(mm)	PRE TENSION(mm)		
GEAR RATIO				
1st SPUR	60T	61T	62T	
1st PINION	19T	<input type="radio"/> 7,58	<input type="radio"/> 7,71	<input type="radio"/> 7,83
	20T	<input type="radio"/> 7,20	<input type="radio"/> 7,32	<input type="radio"/> 7,44
2nd SPUR	56T	57T	58T	
2nd PINION	24T	<input type="radio"/> 5,60	<input type="radio"/> 5,70	<input type="radio"/> 5,80
	25T	<input type="radio"/> 5,38	<input type="radio"/> 5,47	<input type="radio"/> 5,57
AERODYNAMIC SETTINGS				
BODY TYPE				
WING POS. (mm)				
BODY POSITION TO BUMPER(mm)				

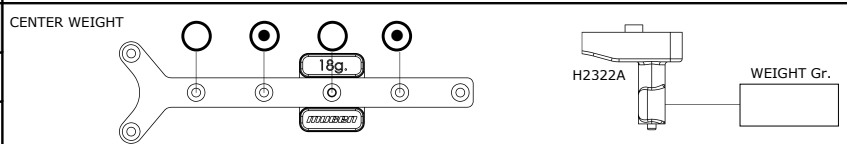
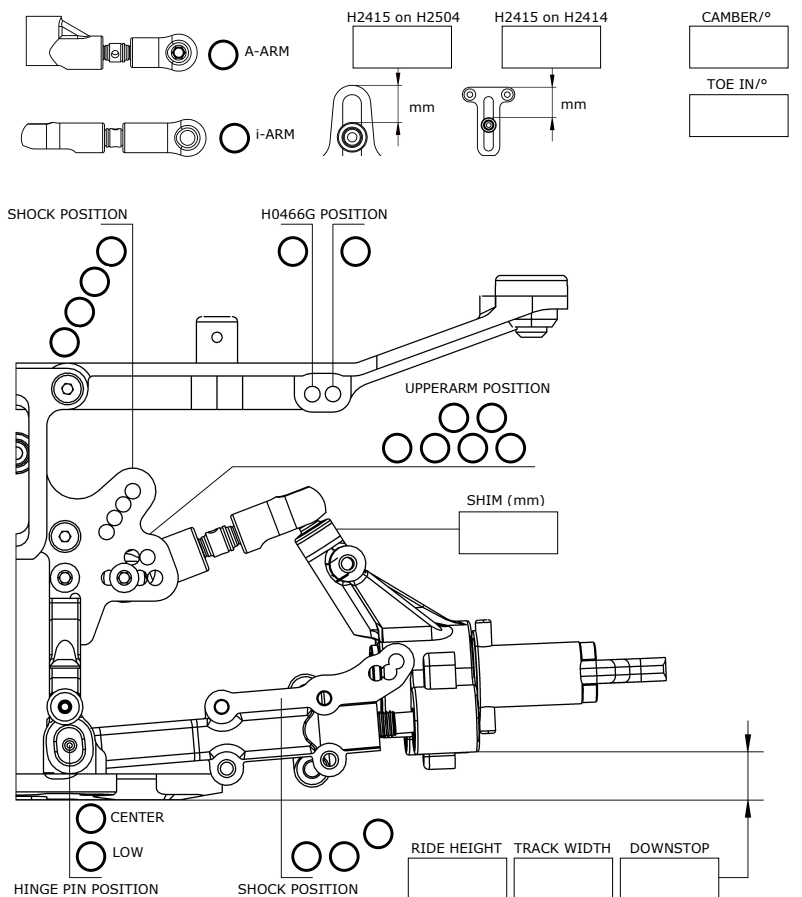
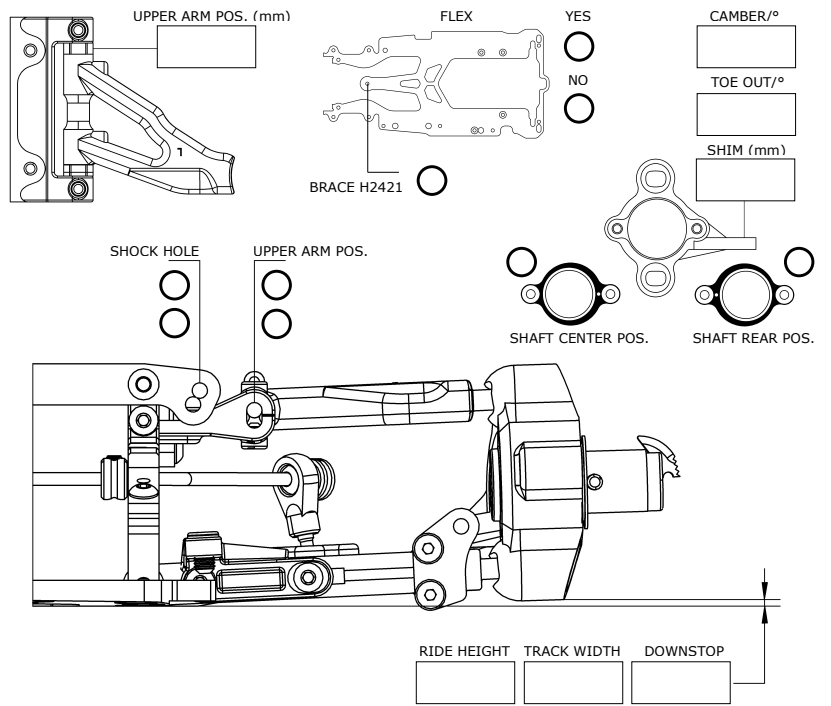

REMARKS