

|        |                                 |  |
|--------|---------------------------------|--|
| DRIVER | <b>Shoki Takahata</b>           |  |
| DATE   | <b>June 2, 2019</b>             |  |
| TRACK  | <b>KeiTune, 2019 Japan Nats</b> |  |

## TRACTION

|                              |  |                               |
|------------------------------|--|-------------------------------|
| LOW <input type="checkbox"/> | MEDIUM <input checked="" type="checkbox"/> | HIGH <input type="checkbox"/> |
|------------------------------|--|-------------------------------|

## LAYOUT

|                               |   |                               |
|-------------------------------|---|-------------------------------|
| SLOW <input type="checkbox"/> | MIXED <input checked="" type="checkbox"/> | FAST <input type="checkbox"/> |
|-------------------------------|---|-------------------------------|

## ENGINE

|                              |                                |             |
|------------------------------|--------------------------------|-------------|
| TYPE                         | <b>O.S Speed R21 Euro Spec</b> |             |
| GLOW PLUG/FUEL PIPE/MANIFOLD | <b>RP7</b>                     | <b>NASA</b> |
|                              | <b>O.S-T-2080</b>              |             |

## CLUTCH SETTINGS

|                               |            |            |
|-------------------------------|------------|------------|
| SHOE#/BELL#                   | <b>KIT</b> | <b>KIT</b> |
| CLEARANCE(mm) / AXIALPLAY(mm) | <b>0.6</b> | <b>0.2</b> |
| SPRING#/TENSION(mm)           | <b>KIT</b> | <b>0.1</b> |

## TYRES

### CONTROLLED

| FRONT     |           | BRAND          | REAR      |           |
|-----------|-----------|----------------|-----------|-----------|
| LEFT      | RIGHT     |                | LEFT      | RIGHT     |
|           |           | <b>Matrix</b>  |           |           |
|           |           | SHORE          |           |           |
| <b>68</b> | <b>68</b> | DIAMETER START | <b>75</b> | <b>75</b> |
|           |           | DIAMETER 5min  |           |           |

## SHOCK ABSORBERS

### FRONT

|        |                    |        |                     |
|--------|--------------------|--------|---------------------|
| PISTON | <b>1.3x1</b>       | PISTON | <b>1.1x2</b>        |
| OIL    | <b>600</b>         | OIL    | <b>600</b>          |
| SPRING | <b>Mugen White</b> | SPRING | <b>Serpent Blue</b> |

### REAR

|                              |                              |   |                              |
|------------------------------|------------------------------|---|------------------------------|
| ANTI ROLL BAR FRONT          |                              |   |                              |
| 2,2 <input type="checkbox"/> | 2,3 <input type="checkbox"/> | 2,4 <input checked="" type="checkbox"/> | 2,5 <input type="checkbox"/> |
| ANTI ROLL BAR REAR           |                              |   |                              |
| 2,8 <input type="checkbox"/> | 2,9 <input type="checkbox"/> | 3,0 <input checked="" type="checkbox"/> |                              |

## SERVO SAVER POSITION

|                                  |                                     |                                   |
|----------------------------------|-------------------------------------|-----------------------------------|
| FORWARD <input type="checkbox"/> | <input checked="" type="checkbox"/> | REARWARD <input type="checkbox"/> |
|----------------------------------|-------------------------------------|-----------------------------------|

## PINION 1st

|                              |   |
|------------------------------|---|
| 15T <input type="checkbox"/> | 16T <input checked="" type="checkbox"/> |
|------------------------------|---|

## PINION 2nd

|                              |   |
|------------------------------|---|
| 19T <input type="checkbox"/> | 20T <input checked="" type="checkbox"/> |
|------------------------------|---|

## SPUR 1st

|                              |                              |   |
|------------------------------|------------------------------|---|
| 48T <input type="checkbox"/> | 49T <input type="checkbox"/> | 50T <input checked="" type="checkbox"/> |
|------------------------------|------------------------------|---|

## SPUR 2nd

|                              |                              |   |
|------------------------------|------------------------------|---|
| 45T <input type="checkbox"/> | 46T <input type="checkbox"/> | 47T <input checked="" type="checkbox"/> |
|------------------------------|------------------------------|---|

## STEERING ROD POSITION

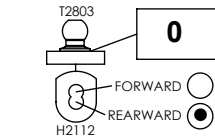

## CASTER ANGLE (mm)

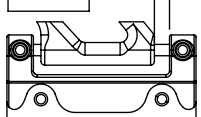
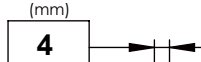

## UPPER ARM POSITION

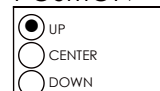

## CAMBER

LEFT **1.2** RIGHT **1.2**



## SHOCK HOLE

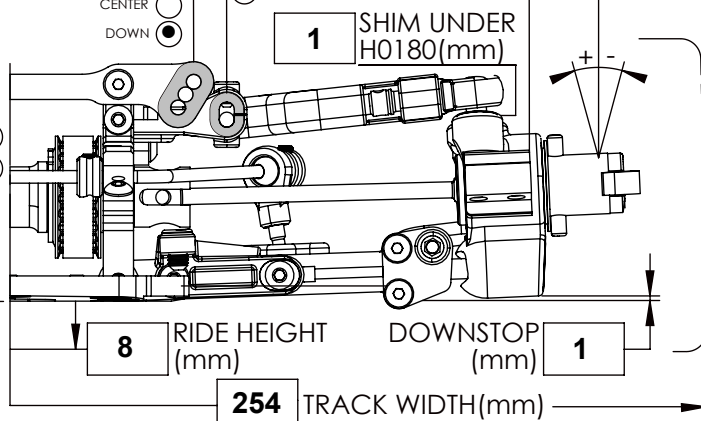
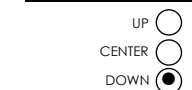

## SHOCK/UPPER ROD POSITION

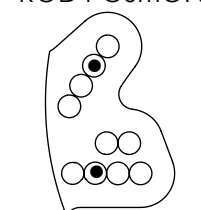

## SHOCK POSITION H2159



## LOWER ARM POSITION

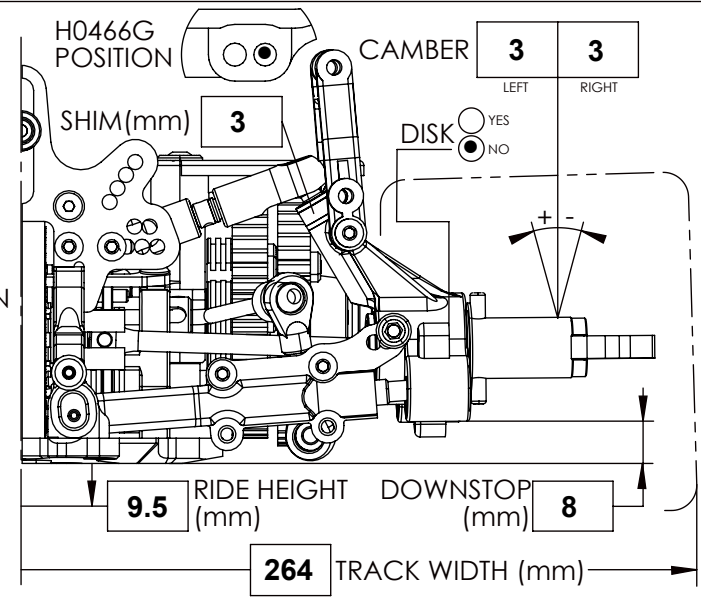
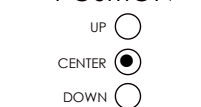

## FRONT TOE

|                 |                  |
|-----------------|------------------|
| LEFT <b>1.5</b> | RIGHT <b>1.5</b> |
|-----------------|------------------|

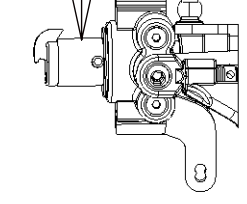

## RADIOPLATE FLEX

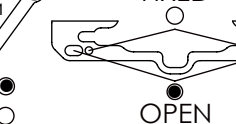

## H2415 MOUNTED ON:

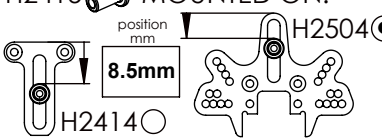

## REAR TOE

|                 |                  |
|-----------------|------------------|
| LEFT <b>2.5</b> | RIGHT <b>2.5</b> |
|-----------------|------------------|

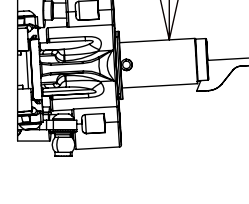

## WEIGHT DISTRIBUTION

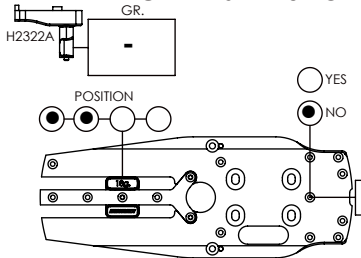

## AERO/SETTING

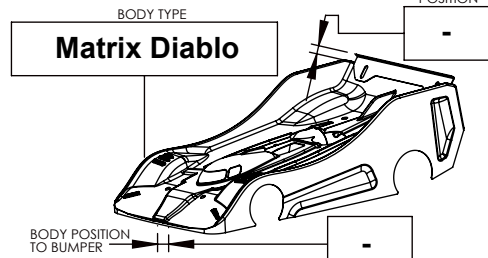

## NOTES:

キャンバー、車高はセッティングゲージで計測  
Measured camber and ride height by setting gauge.

フロントメカプレートH2421はYurugix製 (YPM-1005) を使用  
Use Yurugix Flex control plate (YPM-1005) instead of H2421.