

| | | |
|--------|----------------------|--|
| DRIVER | Takehiro Terauchi | |
| DATE | 2017/11/5 | |
| TRACK | SRT, 2017 Japan Nats | |

| TRACTION | | |
|------------------------------|--|-------------------------------|
| LOW <input type="checkbox"/> | MEDIUM <input checked="" type="checkbox"/> | HIGH <input type="checkbox"/> |

| LAYOUT | | |
|-------------------------------|---|-------------------------------|
| SLOW <input type="checkbox"/> | MIXED <input checked="" type="checkbox"/> | FAST <input type="checkbox"/> |

| ENGINE | | |
|--------|--|--|
|--------|--|--|

| | | |
|------------------------------|----------|---------|
| TYPE | Picco R1 | |
| GLOW PLUG/FUEL PIPE/MANIFOLD | 7 | NASA 25 |
| | 2116 | |

| CLUTCH SETTINGS | | |
|-----------------|--|--|
|-----------------|--|--|

| | | |
|-----------------------------|--------|------|
| SHOE#/BELL# | Yellow | Alm. |
| CLEARANCE(mm)/AXIALPLAY(mm) | 0.6 | 0.1 |
| SPRING#/TENSION(mm) | STD | 0 |

| TYRES | | |
|--|--|--|
| CONTROLLED <input checked="" type="checkbox"/> | | |

| FRONT | | REAR | |
|-------|-------|----------------|-------|
| LEFT | RIGHT | LEFT | RIGHT |
| | | SHORE | |
| | | DIAMETER START | |
| 68 | 68 | 75 | 75 |
| | | DIAMETER 5min | |

| SHOCK ABSORBERS | | | |
|-----------------|--|------|--|
| FRONT | | REAR | |

| | | | |
|--------|-----------|--------|-------|
| PISTON | 1.1x2 | PISTON | 1.1x2 |
| OIL | 500 | OIL | 600 |
| SPRING | SPT Green | SPRING | Gray |

| ANTI ROLL BAR FRONT | | | |
|------------------------------|---|------------------------------|------------------------------|
| 2,2 <input type="checkbox"/> | 2,3 <input checked="" type="checkbox"/> | 2,4 <input type="checkbox"/> | 2,5 <input type="checkbox"/> |

| ANTI ROLL BAR REAR | | | |
|------------------------------|---|------------------------------|--|
| 2,8 <input type="checkbox"/> | 2,9 <input checked="" type="checkbox"/> | 3,0 <input type="checkbox"/> | |

| SERVO SAVER POSITION | | | |
|----------------------|--|--|--|
|----------------------|--|--|--|

| | | | |
|---|-----------------------------------|----------------------------------|--|
| FORWARD <input checked="" type="checkbox"/> | REARWARD <input type="checkbox"/> | FORWARD <input type="checkbox"/> | REARWARD <input checked="" type="checkbox"/> |
|---|-----------------------------------|----------------------------------|--|

| PINION 1st | |
|---|------------------------------|
| 15T <input checked="" type="checkbox"/> | 16T <input type="checkbox"/> |

| PINION 2nd | |
|---|------------------------------|
| 19T <input checked="" type="checkbox"/> | 20T <input type="checkbox"/> |

| SPUR 1st | | |
|---|------------------------------|------------------------------|
| 48T <input checked="" type="checkbox"/> | 49T <input type="checkbox"/> | 50T <input type="checkbox"/> |

| SPUR 2nd | | |
|------------------------------|---|------------------------------|
| 45T <input type="checkbox"/> | 46T <input checked="" type="checkbox"/> | 47T <input type="checkbox"/> |

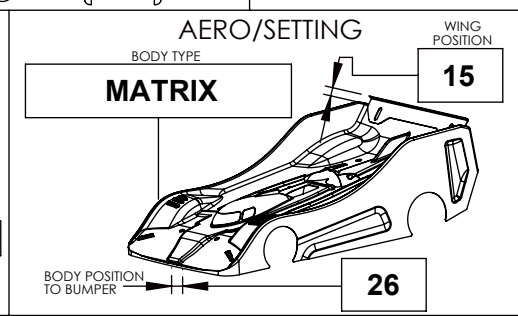
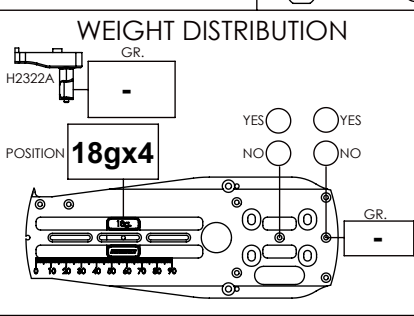
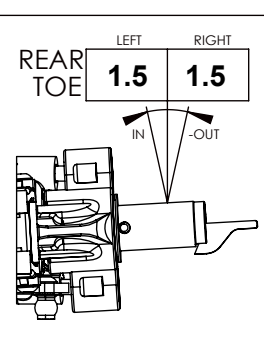
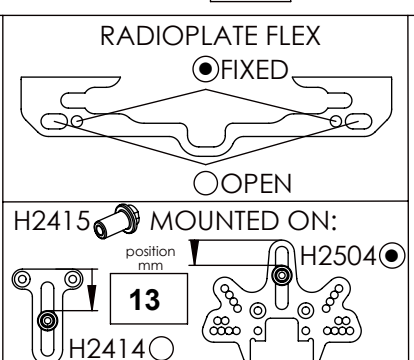
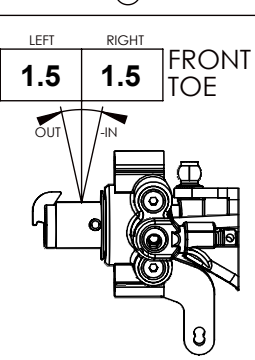
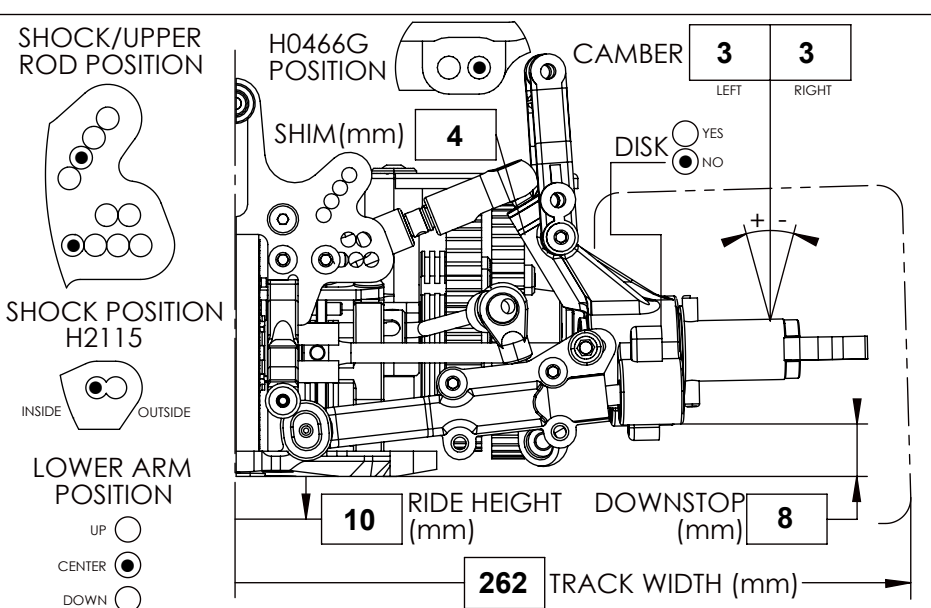
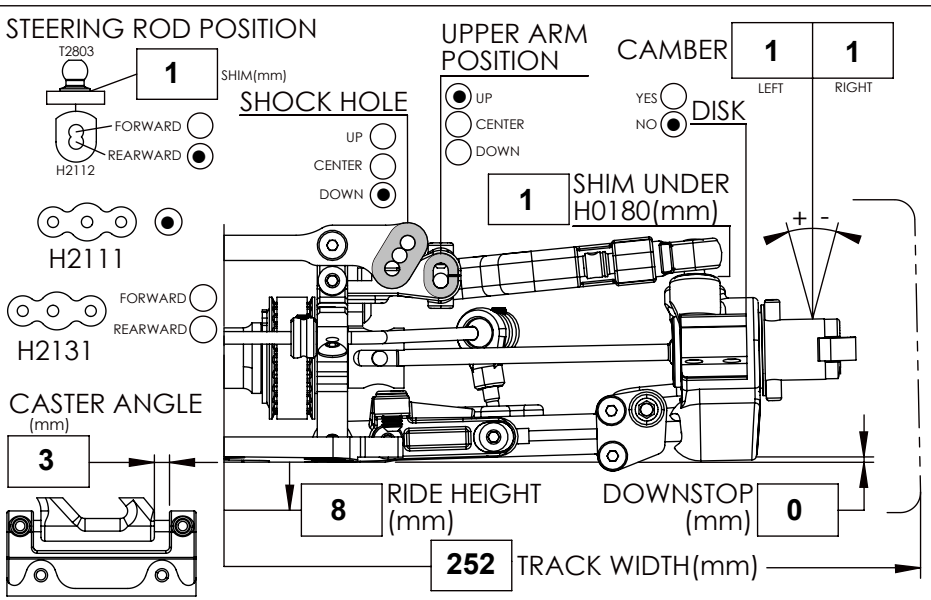

NOTES:

- * Use Proto-type chassis and rear lower bulkhead
プロトタイプのシャーシとリヤローワーバルクヘッドを使用
- * Use 15gx2 weights diagonally behind the fuel tank
タンクの斜め後ろに15gX2ヶ