

Name: Mike Swauger
Date: 09 U.S Nationals
Track: Toledo, Oh

Track Conditions

Size: Open Med. Tight
 Traction: High Med. Low
 Surface: Smooth Med. Bumpy

Front suspension

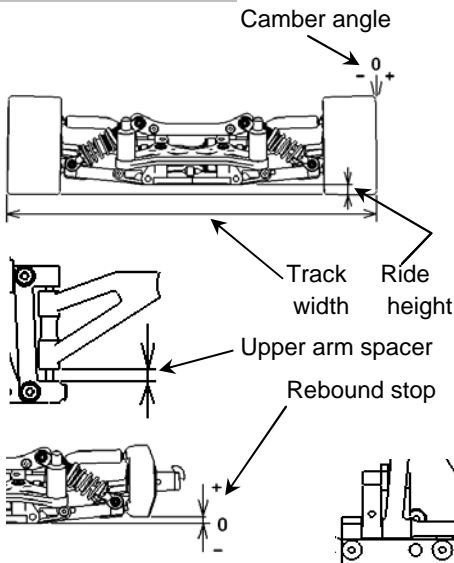

Track width 253 mm
 Ride height 6.0 mm
 Camber angle 2 °
 Upper arm spacer 2 mm
 Toe angle out 1 °
 Rebound stop 0 mm
 Bump stop None Use
 Lower arm spacer 0 mm
 Upper arm position 1 mm
 Anti-roll bar

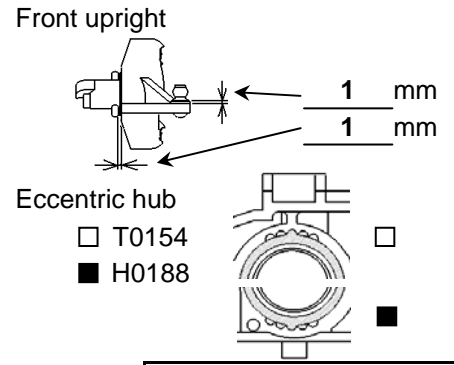

Steering ackerman

A
 B
 C
 D

Rear suspension

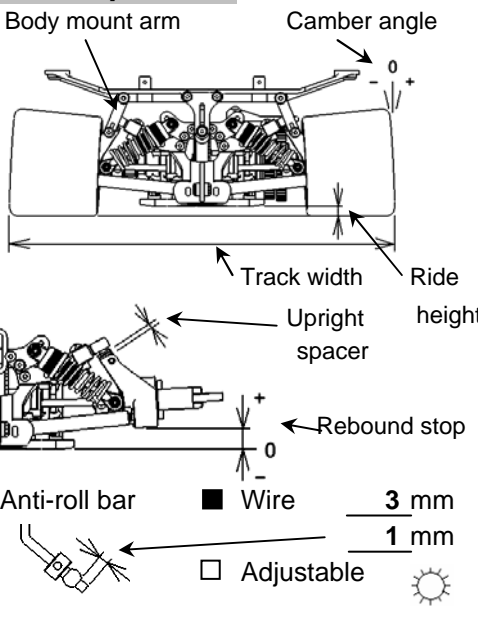

Track width 263 mm
 Ride height 7.0 mm
 Camber angle 3.5 °
 Toe angle in 1.5 °
 Rebound stop 9 mm
 Bump stop None Use
 Lower arm position (H0134)
 4.5mm 5mm 5.5mm
 Upright spacer 2 mm
 Upper arm position
 H0466C (Short)
 H0466F (Long)
 Body mount arm
 H0466C (Short)
 H0466F (Long)

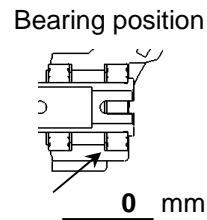

Front shock

Piston Stock
 Oil # 600
 Springs Grey
 Shock position

Rear shock

Piston Stock
 Oil # 600
 Springs Grey
 Shock position

Engine Type Novarossi Flash Muffler Nova 2015
 Gasket _____ mm Manifold Short
 Plug MSR Prototype Fuel MSRF 25%

Clutch
 Clutch shoe Yellow Gray Red
 Centrifugal shoe One 4mm hole
 Spring MSR
 Clutch bell clearance 0.4 mm
 Spring adj. nut position 0.8 mm

Tire <Front> Type Enneti 32 <Rear> Type Enneti 35
 Dia.(start) L 65 /R Dia.(start) L 72 /R
 Dia.(finish) L /R Dia.(finish) L /R

Brake pad Black Yellow

Body Type Protoform 909
 Body position 12.5 mm
 Rear spoiler 2 mm

Drive ratio Gear ratio Side pulley
 1st. 16/49 25T
 2nd. 20/47 26T

Result
 Race time / Lap _____
 Best lap (1Lap) _____

Comments: 3 mm Short wheelbase in the rear
Rear Universals
"R" Rear hub Carrier