

**Name:** Yusuke Sugiura  
**Date:** November 17, 2019  
**Track:** Futaba Buggy Tract Japan Nats

### Track conditions

Size:  Open  Med.  Tight  
 Traction:  High  Med.  Low  
 Surface:  Smooth  Med.  Bumpy

### Result

Race time / Lap: \_\_\_\_\_  
 Best lap (1Lap): 39'7

### Front suspension

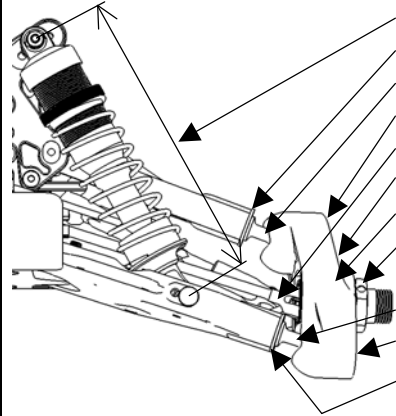

Rebound stop: 104mm  
 Kingpin ball spacer: 1.0mm  
 E0160  E2123(Steel)  
 E0159  E2124(Steel)  
 E2218  E0220(CVD)  
 E2153  E2168(-3)  
 E2146  E2147(1.5)  
 E0239  E0240(1mm)  
 E0160  E2123(Steel)  
 E0159  E2124(Steel)  
 Kingpin ball spacer: 0.5mm

Ride height: 23mm  
 Toe angle: Out 1°  
 Lower arm plate:  
 E2144A,B  
 E2154(CFRP 1mm)  
 E2155(CFRP 1.2mm)  
 Anti roll bar:  $\phi$  2.3  
 Upper arm spacer: 2

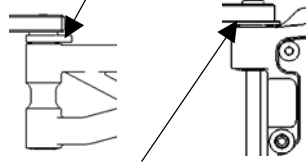

Upper arm position:

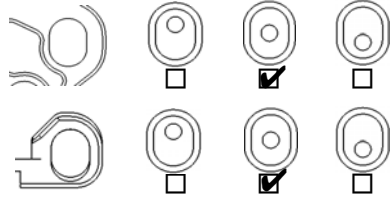

Lower arm position (Kick up):

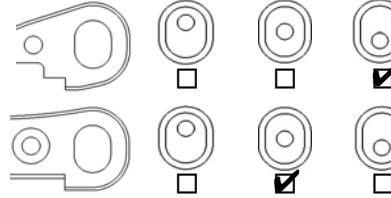

### Front shocks

Piston: MIP Oil: #500  
 Spring:  $\phi$  1.6 L70/9.25T

Shock position:

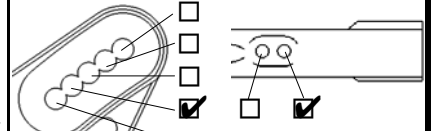

Pivot ball position:  Front  Rear  
 Damper stay:  E2562(Aluminum)  
 E2565(CFRP)

### Steering ackerman

Front

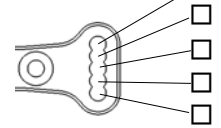

### Front upper plate

E2148D  E2158(CFRP)

### Servo saver arm

E2301A  E2310(Aluminum)

### Rear suspension

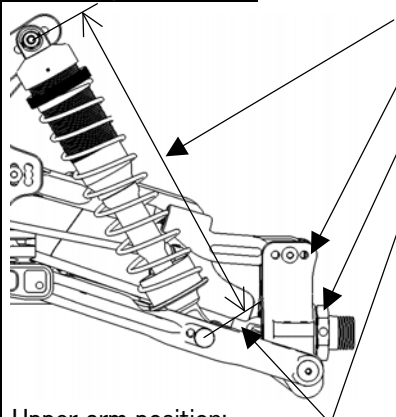

Rebound stop: 118mm  
 E2131  E2134(Aluminum)  
 E0239  E0240(1mm)  
 E2219  E0220(CVD)  
 E0241(2mm)

Ride height: 29mm  
 Camber angle: -2.5  
 Lower arm plate:  
 E2145A,B  
 E2156(CFRP 1mm)  
 E2157(CFRP 1.2mm)  
 Anti roll bar:  $\phi$  2.7  
 Lower arm spacer: 0mm

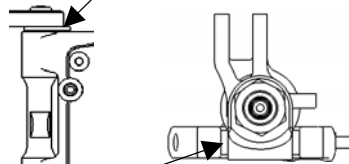

Upper arm position:

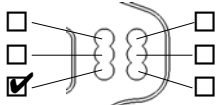

Lower arm position:

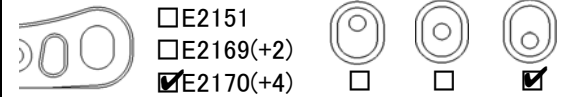

Lower arm position:

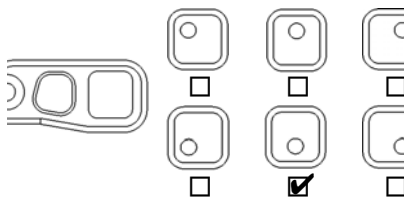

### Rear shocks

Piston: MIP Oil: #450  
 Spring:  $\phi$  1.6 L86/10.75T

Shock position:

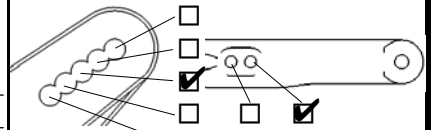

Pivot ball position:  Front  Rear  
 Damper stay:  E2563(Aluminum)  
 E2566(CFRP)

### Center shaft

E2228,E2229

E0223,E0259(CVD)  E2261,E2262

### Tension rod

Front:  E2107A(Long)  E2107B(Short)

Rear:  E2148C  E0803(Rubber)

### Weight



### Engine

Type: O.S. B2103 TypeS Plug: P3 Reducer:  $\phi$  6  
 Muffler: 2090 Fuel: Klotz Fast Time30 Gasket: 0.35  
 Engine mount:  E0701(Standard)  E2713(One piece)

### Diff. gear

Oil  
 Front:  44/13T  42/12T #6,000  
 Rear:  44/13T  42/12T #2,000  
 Center:  44T  45T  46T #6,000  
 47T  48T

### Tires

#### Front

Type: Pro-Line Fugitive  
 Compound: S4  
 Inserts: Closed Cell Inserts  
 Wheel: Mugen

#### Rear

Type: Pro-Line Fugitive  
 Compound: S4  
 Inserts: Closed Cell Inserts  
 Wheel: Mugen

### Clutch

Clutch bell:  13T  14T

	$\phi$ 0.9	$\phi$ 0.95	$\phi$ 1.0	$\phi$ 1.05	$\phi$ 1.1
A	<input type="checkbox"/> C0754 <input type="checkbox"/> E0704 <input checked="" type="checkbox"/> E0710				<input checked="" type="checkbox"/>
B	<input type="checkbox"/> C0754 <input type="checkbox"/> E0704 <input checked="" type="checkbox"/> E0710				<input checked="" type="checkbox"/>
C	<input checked="" type="checkbox"/> C0754 <input type="checkbox"/> E0704 <input type="checkbox"/> E0710				<input checked="" type="checkbox"/>

### Body/Wing

Body: JConcepts S15  
 Wing: Mugen  
 Wing stay:  E2422A  E2428A(+15)  
 Wing position:

### Comments

MIP Bypass 1.2x8H pistons with clear valve