

Name: Aaron Stringer
 Date: November 2018
 Track: 2018 Worlds Perth

Track conditions

Size: Open Med. Tight
 Traction: High Med. Low
 Surface: Smooth Med. Bumpy

Result

Race time / Lap: _____
 Best lap (1Lap): _____

Front suspension

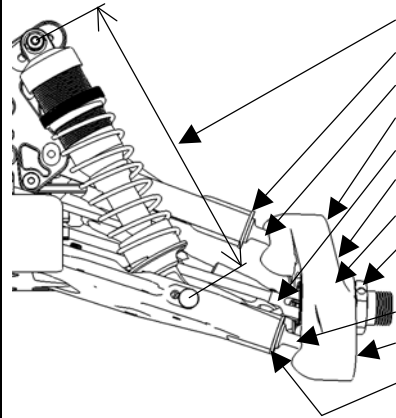

Rebound stop: 105mm
 Kingpin ball spacer: 1mm
 E0160 E2123(Steel)
 E0159 E2124(Steel)
 E2218 E0220(CVD)
 E2153 E2168(-3)
 E2146 E2147(1.5)
 E0239 E0240(1mm)
 E0239 E0241(2mm)
 E0160 E2123(Steel)
 E0159 E2124(Steel)
 Kingpin ball spacer: 1mm

Ride height: 24mm
 Toe angle: Small amount out
 Lower arm plate: E2144A,B
 E2154(CFRP 1mm)
 E2155(CFRP 1.2mm)
 Anti roll bar: φ 2.4
 Upper arm spacer: Middle

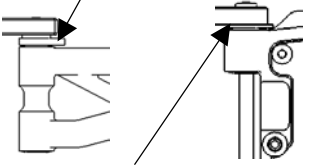

Upper arm position:

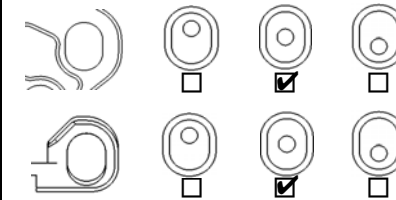

Lower arm position (Kick up):

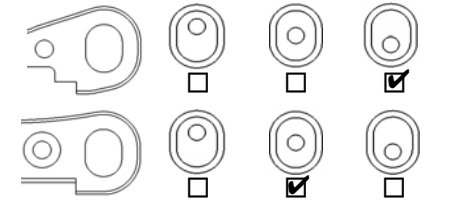

Front shocks

Piston: 5x1.5 Oil: #650
 Spring: 9.0 x 70
 Shock position:

 Pivot ball position: Front Rear
 Damper stay: E2562(Aluminum)
 E2565(CFRP)

Steering ackerman

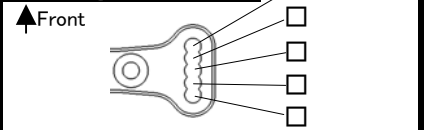

Front upper plate

E2148D E2158(CFRP)

Servo saver arm

E2301A E2310(Aluminum)

Rear suspension

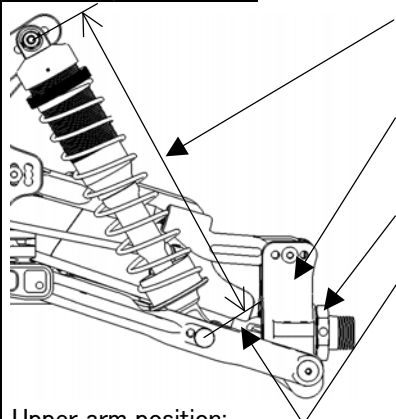

Rebound stop: 123mm
 E2131
 E2134(Aluminum)
 E0239 E0240(1mm)
 E2219 E0241(2mm)
 E2219 E0220(CVD)

Ride height: 26mm
 Camber angle: 3°
 Lower arm plate: E2145A,B
 E2156(CFRP 1mm)
 E2157(CFRP 1.2mm)
 Anti roll bar: φ 2.7
 Lower arm spacer: 1mm

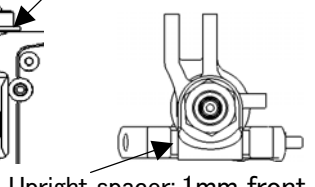

Upper arm position:

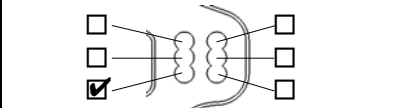

Lower arm position (Anti-squat):



Rear shocks

Piston: 5x1.5 Oil: #500
 Spring: 10.5
 Shock position:

 Pivot ball position: Front Rear
 Damper stay: E2563(Aluminum)
 E2566(CFRP)

Center shaft

E2228,E2229
 E0223,E0259(CVD) E2261,E2262

Tension rod

Front: E2107A(Long) E2107B(Short)
 Rear: E2148C E0803(Rubber)

Weight



Engine

Type: O.S. Speed B2101 Plug: _____ Reducer: 6mm
 Muffler: 2060 Fuel: _____ Gasket: _____
 Engine mount: E0701(Standard) E2713(One Piece)

Diff. gear

Oil
 Front: 44/13T 42/12T #10,000
 Rear: 44/13T 42/12T #4,000
 Center: 44T 46T #7,000
 47T 48T

Tires

	Front	Rear
Type:	<u>AKA Double Down</u>	<u>AKA Double Down</u>
Compound:	<u>Soft - Long wear</u>	<u>Soft - Long wear</u>
Inserts:	<u>Red</u>	<u>Red</u>
Wheel:	_____	_____

Clutch

	Clutch bell:	Oil				
		φ 0.9	φ 0.95	φ 1.0	φ 1.05	φ 1.1
A	<input checked="" type="checkbox"/> C0754 <input type="checkbox"/> E0704 <input type="checkbox"/> E0710	<input checked="" type="checkbox"/>				
B	<input checked="" type="checkbox"/> C0754 <input type="checkbox"/> E0704 <input type="checkbox"/> E0710		<input checked="" type="checkbox"/>			
C	<input checked="" type="checkbox"/> C0754 <input type="checkbox"/> E0704 <input type="checkbox"/> E0710			<input checked="" type="checkbox"/>		

Body/Wing

Body: LFR Tactic 2
 Wing: Standard
 Wing stay: E2422A E2428A(+15)
 Wing position:
 Front

Comments

Red ultimate bladders, ran my custom +5mm higher shock tower with truggy rear shocks
 Ran 44 - 12 diff gearing with 44 spur