

Name: Robert Batlle
Date: 2014/3/14
Track: Pdova (Italy)

Track Conditions
Size: Open Med. Tight
Traction: High Med. Low
Surface: Smooth Med. Bumpy

Result
Race Time / Lap: _____
Best Lap (1Lap): _____

Front Suspension

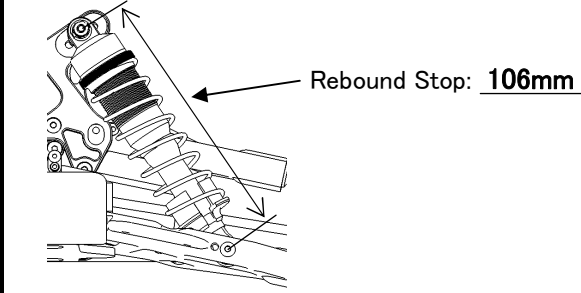

Tension Rod: E2107A(Long)
 E2107B(Short)

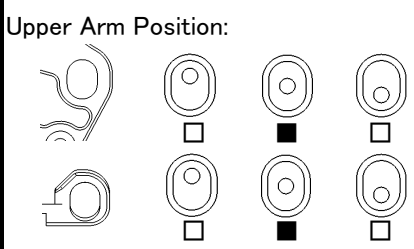

Ride Height: **24mm**
Toe Angle: **out 1°**
Kingpin Ball Spacer: **1**
Wheel Hub: **1**
Anti Roll Bar: **φ2.3**
Upper Arm Spacer: **1mm**

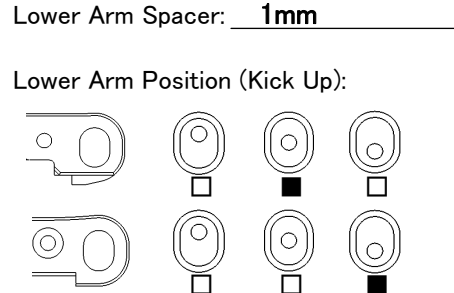
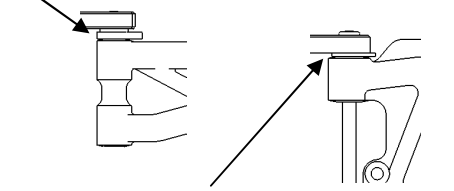

Front Shocks

Piston: **1.2x8Hole**
Oil: **#550 Ultimate**
Spring: **9.5T**
Spring Adj: _____

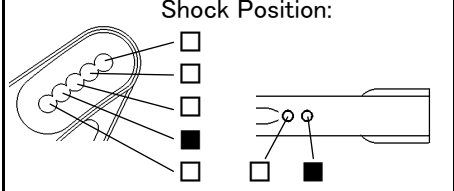

Pivot Ball Position: Front Rear
Damper Stay: E2502(Aluminum)
 E2511(CFRP)

Steering Ackerman

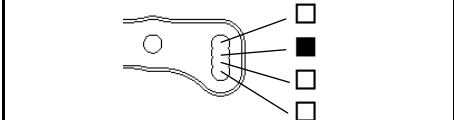

Rear Suspension

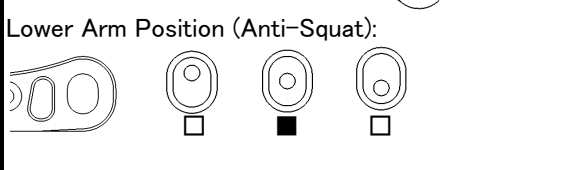
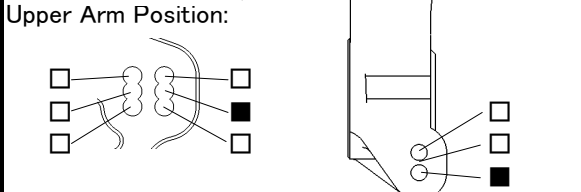
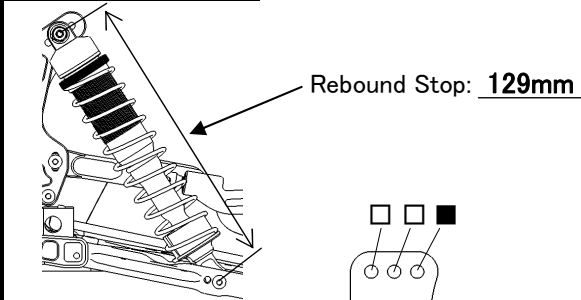

Ride Height: **29mm**
Camber Angle: **2°**
Wheel Hub: **1**
Anti Roll Bar: **φ2.7**
Lower Arm Spacer: **1mm**

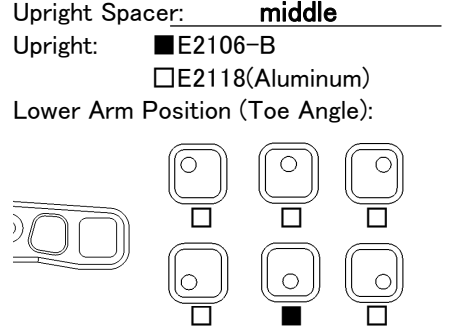
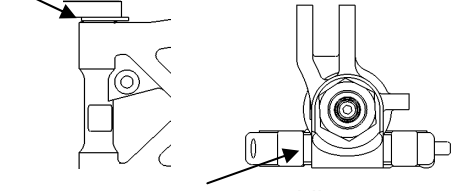

Rear Shocks

Piston: **1.2x8Hole**
Oil: **#500 Ultimate**
Spring: **10.75T**
Spring Adj: _____

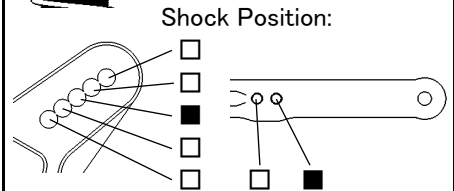

Pivot Ball Position: Front Rear
Damper Stay: E2503(Aluminum)
 E2514(CFRP)

Engine

Type: **NOVAROSSİ BTTS** **Plug:** _____
Gasket: _____ **Reducer:** _____
Muffler: _____ **Fuel:** _____
Engine Mount: E0701(Standard) E0703(One Piece)

Diff. Oil

Front: **#5000** **O-Ring:** _____ pcs.
Center: **#7000** _____ pcs.
Rear: **#5000** _____ pcs.

Tires

Front **Rear**
Type: **PROCIRCUIT** **PROCIRCUIT**
Compound: _____
Inserts: _____
Wheel: _____

Clutch

Clutch Bell: **RBR36** **Spur Gear:** _____
Clutch Shoes: **Alu**
Clutch Spring: **φ1.0**

Body/Wing

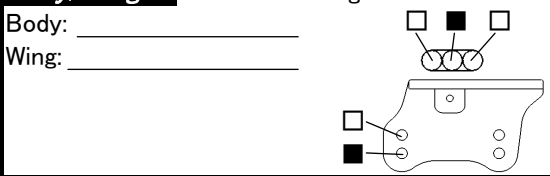

Comments

.....

