

Name: Renaud Savoya
Date: December 9-13, 2009
Track: Buggy Party in Pattaya, Thailand

Track Conditions

Size: Open Med. Tight
 Traction: High Med. Low
 Surface: Smooth Med. Bumpy

Front Suspension

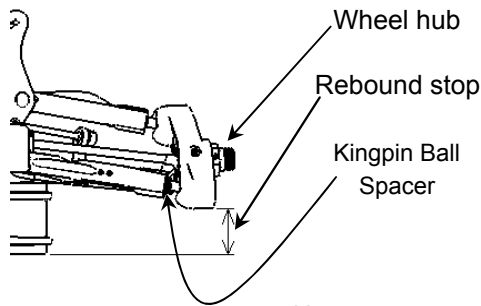

Kingpin ball spacer stock mm
 Camber angle -5 °
 Upper arm spacer 0 mm
 Toe angle 2 °
 Rebound stop maxi mm
 Anti-roll bar ϕ 2.3 mm
 Wheel Hub 0 mm
 Lower arm mount (Kick up) 0 1



Lower arm plate (E0154A)

Upper arm position (E0148B, E0148C)

Lower arm spacer 0 mm

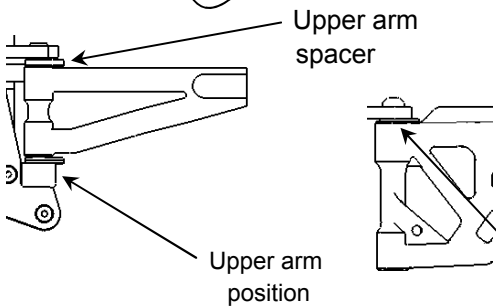

Front Shocks

Piston standard
 Oil # 700
 Spring Ultimate
 Spring adjustmer 6 mm

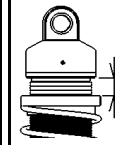

Shock position



Steering Ackerman

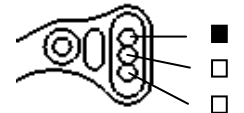

Rear Suspension

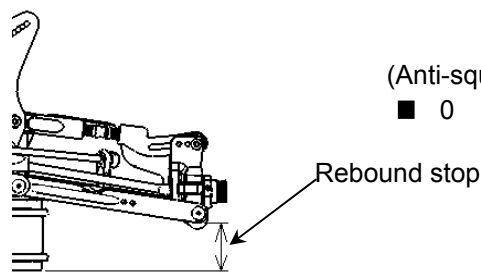

Camber angle -6 °
 Lower arm mount (Anti-squat) 0 1
 (Toe angle) 2.50 °
 Rebound stop maxi mm
 Anti-roll bar ϕ 3.2 mm
 Anti-squat (E0111C, E0111D)



Upright E0152 E0173(Aluminium)

Wheelbase adjustment 0 mm

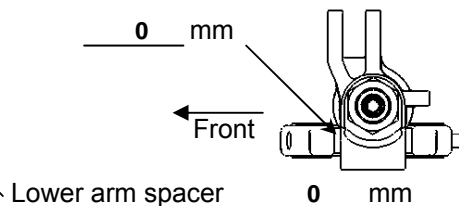
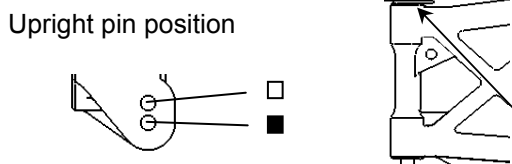
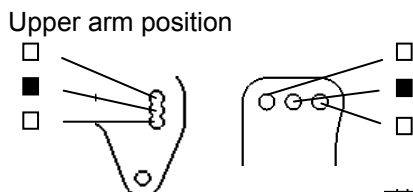

Rear Shocks

Piston standard
 Oil # 600
 Spring Ultimate
 Spring adjustmer 10 mm

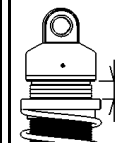

Shock position

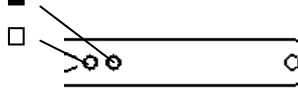
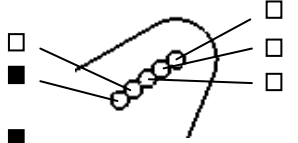

Wing Position

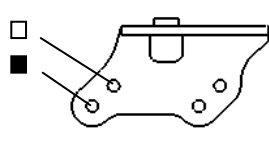

Engine Type RB B9
 Gasket mm Reducer ϕ 7.0
 Plug C6 Fuel
 Muffler EFRA 2045+manifold 192P Compact

Diff. Oil
 Front # 15000 O-Ring 0 pcs. Other
 Center # 15000 0 pcs. Other
 Rear # 10000 0 pcs. Other

Tire
Front
 Type Caliber M3
 Foam Evo
Rear
 Type Caliber M3
 Foam Evo

Clutch Clutch shoes Aluminium
 Other
 Spring 1.0 mm
 Clutch bell / Spur gear 13T / 46T

Result
 Race time / Lap
 Best lap (1Lap)

Comments:
Overdrive conical gear on the rear drive train
Camber angle set chassis on the ground